

FEATURES & ZUBEHÖR

FEATURES & ADDITIONAL EQUIPMENT



Features & Zubehör

Features & additional equipment

PLANLICHT FEATURES & ZUBEHÖR IM ÜBERBLICK

FEATURES & ADDITIONAL EQUIPMENT AT A GLANCE

STEUERUNGEN | CONTROLS

RADIO CONTROLS



DALI



CASAMBI

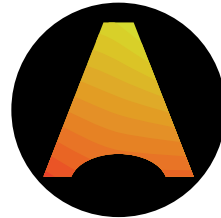

MATTER



BETRIEBSGERÄTE | DRIVERS

CC CONVERTER

CC

CV CONVERTER

CV

KOMPONENTEN FÜR SYSTEME | COMPONENTS FOR SYSTEMS

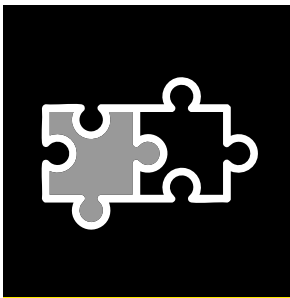

NOTLICHT & SENSOREN | EMERGENCY LIGHTING & SENSORS

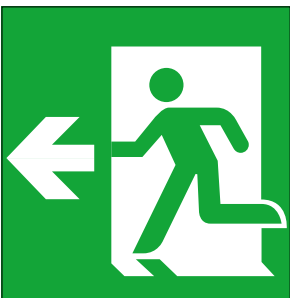

STEUERUNGEN | CONTROLS



RADIO CONTROLS

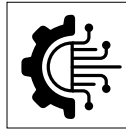

Technologie

Funk, kabellos

Technology

Radio, wireless

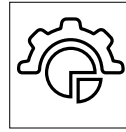

Anwendungsbereiche

24V DC LED-Bänder (1-4 Kanäle, einfarbig, dynamisch weiß, RGB, RGBW)

Application areas

24V DC LED strips (1-4 channels, monochrome, dynamic white, RGB, RGBW)

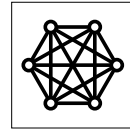

Komplexität

Keine Vorkenntnisse notwendig

Complexity

No prior knowledge required

RADIO CONTROL 24V (1-4 channel)

1-4 channel radio control
2,4 GHz, 4 x max. 2,5 A (240W total)

24V / DC

45AA40PDLU0000B



REMOTE CONTROL

1/2 channel remote control
2,4 GHz (DIM, tunable white)

Dimension
LxWxH=150x40x20 mm

45AA40RCDIMCT0N



REMOTE CONTROL

3/4 channel remote control
2,4 GHz (RGB, RGBW)

Dimension
LxWxH=150x40x20 mm

45AA40RCRGBW00N



TOUCH PANELS FOR RADIO CONTROL

1 channel DIM radio touch panel
2,4 GHz

230V / AC
Dimension
LxWxH=150x40x20 mm

45AA40WALLDIM2B



TOUCH PANELS FOR RADIO CONTROL
2 channel TW radio touch panel
2,4 GHz

230V / AC
Dimension
LxWxH= 150x40x20 mm

45AA40WALLCT20B

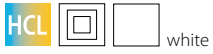

TOUCH PANELS FOR RADIO CONTROL
3 channel RGB radio touch panel
2,4 GHz

230V / AC
Dimension
LxWxH= 150x40x20 mm

45AA40WALLRGB2B

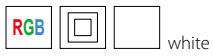

TOUCH PANELS FOR RADIO CONTROL
4 channel RGBW radio touch panel,
2,4 GHz

230V / AC
Dimension
LxWxH= 150x40x20 mm

45AA40WALLRGBW2B

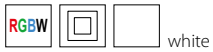



DALI CONTROLS

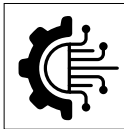

Technologie

Digitales Protokoll, kabelgebunden
(2 × 1,5 mm²)

Technology

Digital protocol, wired (2 × 1.5 mm²)

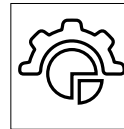

Anwendungsbereiche

Alle Anwendungsgebiete bis maximal 64
Adressen

Application areas

*All application areas up to a maximum of
64 addresses*

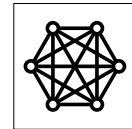

Komplexität

Einsteigerfreundlich bis komplex

Complexity

Beginner-friendly to complex

DALI MCU TW G2

230V / AC IP20
Dimension
LxWxH=80x80x50 mm

540-224673



DALI Steuereinheit mit integrierter Spannungsversorgung (52mA) für Standard DALI und DALI DT8 Anwendungen. Drehpotentiometer integriert, bis zu 4 DALI MCU in einem DALI Kreis möglich. Synchronisation erfolgt automatisch. Einfache Speicherung der Einschaltelligkeit (Doppelklick).

DALI control unit with integrated power supply (52mA) for standard DALI and DALI DT8 applications. Integrated rotary potentiometer, up to 4 DALI MCU in one DALI circuit possible. Automatic synchronisation and simple storage of the switch-on brightness (double-click).



DALI PCU TW G2

230V / AC IP20
Dimension
LxWxH=48x49x22 mm
2x push-button connections (2nd only
for DT8 applications, length of 15cm, up
to 1m possible)

540-631625

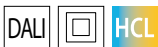

DALI Steuereinheit mit integrierter Spannungsversorgung (52mA) für Standard DALI und DALI DT8 Anwendungen. Kann mit jedem handelsüblichen Taster (Schließer) betrieben werden. Bis zu 4 DALI PCU in einem DALI Kreis möglich. Synchronisation erfolgt automatisch. Einfache Speicherung der Einschaltelligkeit (Doppelklick).

DALI control unit with integrated power supply (52mA) for standard DALI and DALI DT8 applications. Can be operated with any commercially available push-button (NO contact). Up to 4 DALI PCU in one DALI circuit possible. Automatic synchronisation and simple storage of the switch-on brightness (double-click).



DALI XC

DALI controller with up to 4
push - button inputs
current consumption 6mA
DALI Steuermodul mit bis zu vier
Tast-/Schalteingängen

3528001716





DALI TOUCHPANEL LUNATONE

Dimension
LxWxH=82,5x111x8,5 mm

429-24035465-BT

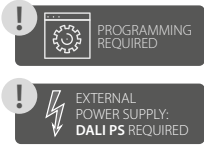

Display Layouts

DYNAMIC WHITE
DALI DT8 only

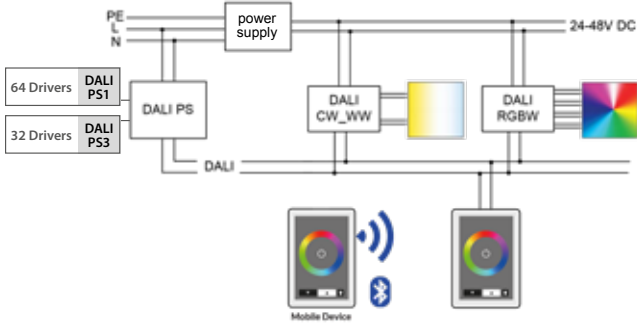
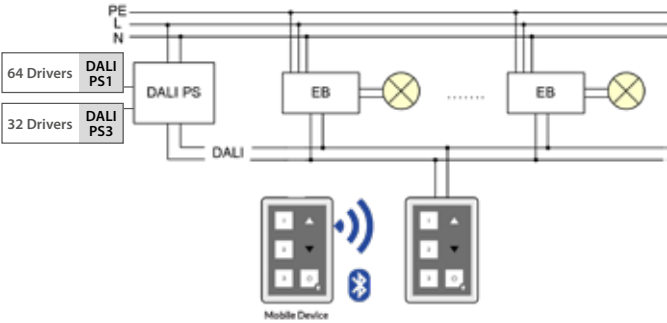

DALI-2 Display 7" Touchpanel

Dimension
LxWxH=178x111x8 mm

429-86456840-W - DALI-2 Display
7" Touchpanel
429-86456840-P-W - DALI-2 Display 7"
Plus Touchpanel



Multifunktionales 7" Dali-2 Touchpanel (24-Bit Farbtiefe) zur Ansteuerung von bis zu 64 Einzeladressen und 16 Gruppen. Zusätzlich geeignet für DT8 Tunable-white, RGB und RGBW-Anwendungen. Individuell gestaltbare Widget-Bedienoberfläche. Integrierte Sensoren zur Visualisierung von Temperatur, Luftqualität, Luftdruck und Luftfeuchtigkeit. Zur Installation an Unterputzdose, Stromversorgung über 24-56V DC oder Power over Ethernet (POE), Leistungsaufnahme 3,5W. Auslieferung erfolgt mit Werkseinstellungen.

„Plus“-Ausführung:
Zusätzlich integrierte Maske zur Adressierung und Inbetriebnahme eines DALI-Systems. Programmierbare zirkadiane Tageslichtfarbverläufe und Timer-Funktionen

Benötigt 24V DC Spannungsversorgung (min. 3,5W), z.B. PMR24 24V

Multifunctional 7" Dali-2 Touchpanel (24-bit color depth) for controlling up to 64 individual addresses and 16 groups. Additionally suitable for DT8 Tunable-white, RGB and RGB applications. Customizable widget-based user interface. Integrated sensors for displaying temperature, air quality, air pressure, and humidity. Designed for installation in wall boxes, powered by 24-56V DC or Power over Ethernet (POE), power consumption of 3.5W. Shipped with factory settings.

„Plus“ version:
Additionally includes an integrated mask for addressing and commissioning a DALI system. Programmable circadian daylight color transitions and timer functions.

Requires 24V DC power supply (min. 3.5W), e.g., PMR24 24V.

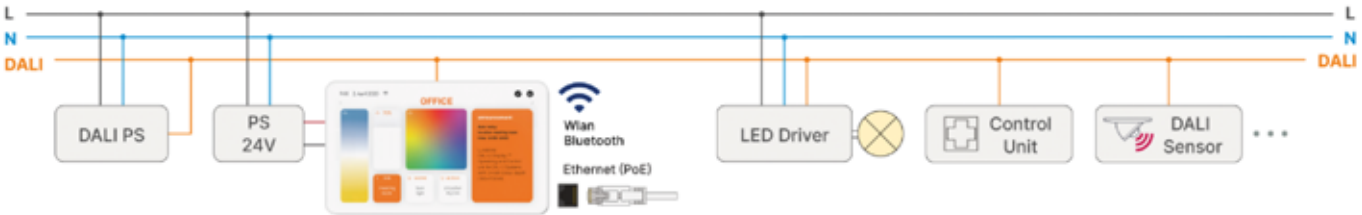

CONTROLS | DALI CONTROLS

DALI PS3

DALI-Stromversorgung für bis zu 70 mA
DALI power supply providing 70 mA

3587500873

32 Drivers **DALI PS3**

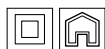

220 - 240V AC



DALI PS1

DALI-Stromversorgung für bis zu 200 mA
DALI power supply providing 200 mA

3524034323

64 Drivers **DALI PS1**

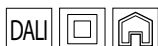

220 - 240V AC



DALI USB

Dimension
 LxWxH= 101,5x51 x29,5 mm
 Current consumption 10 mA

3524138923

DALI

DALI-USB Schnittstelle zur Adressierung von DALI Betriebsgeräten über die Software Master Configurator.

DALI-USB interface for addressing and parameterizing a DALI installation.

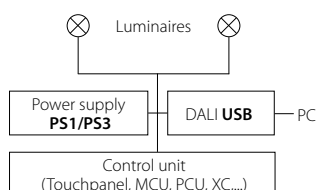

DALI Controller

DALI-DT6 4Ch LED Dimmer CV

Dimension
 LxWxH= 120x30x22 mm

429-86459560



DALI / SwitchDim2

2 mA | max. 10 A | 12V/DC-48V/DC

Betriebsart DT6: 4 DALI-Adressen | *DT6 operating mode: 4 DALI addresses*

Betriebsart Colour & Dim: 2 DALI-Adressen | *Colour & Dim operating mode: 2 DALI addresses*



DALI-DT8 RGBW LED Dimmer CV

Dimension
 LxWxH= 120x30x22 mm

429-89453840



DALI / SwitchDim2

2 mA | max. 10 A | 12V/DC-48V/DC

Betriebsart DT8: 1 DALI-Adresse | *DT8 operating mode: 1 DALI address*

Betriebsart Colour & Dim: 2 DALI-Adressen | *Colour & Dim operating mode: 2 DALI addresses*





CASAMBI Bluetooth Controls

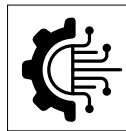

Technologie
Bluetooth, kabellos

Technology
Bluetooth, wireless

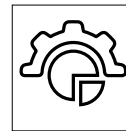

Anwendungsbereiche
Alle Anwendungsgebiete bis 125 Geräte

Application areas
All application areas up to 125 devices

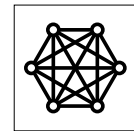

Komplexität
Einstiegerfreundlich bis komplex

Complexity
Beginner-friendly to complex

basicDIM Wireless Modul G2
Bluetooth 4.0, 230V / AC
Control unit for max. 5 LED converters
(max. 10mA / DC)

Dimension
LxWxH=80,7x30x15,3 mm

3528003540



→ DALI 2
220-240V AC

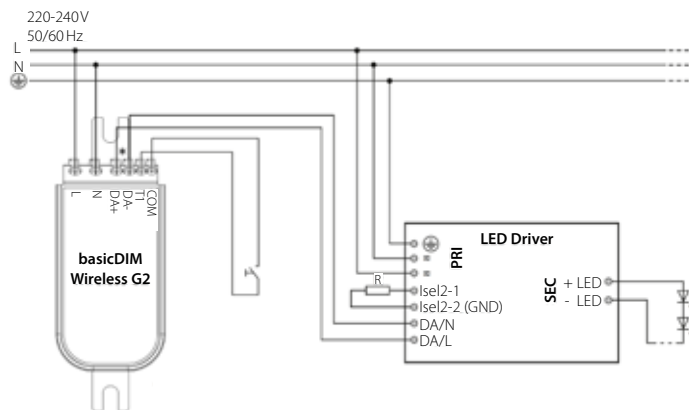

basicDIM Wireless Modul Passive G2
Bluetooth 4.0
Passive DALI-2 control unit without integrated DALI power supply
current consumption 4mA

Dimension
LxWxH=80,7x30x15,3 mm

3528003541



→ DALI 2

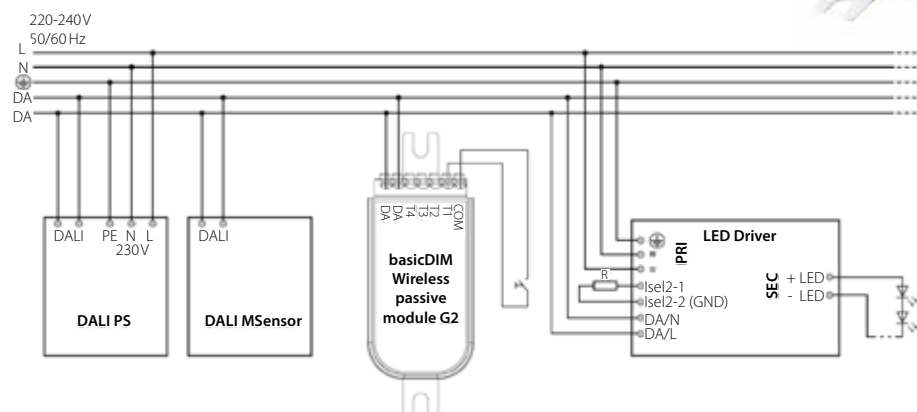

MSensor G3 PIR 5DPI
 (optional accessory to basicDIM Wireless
 Modul Passive G2)
 current consumption 9mA

3528002384
3528002386
3528002878 (Surface mounting kit for
 3528002384)



3528002384



3528002878



3528002386

basicDIM Wireless SR
 Bluetooth 4.0, 230V/AC
 Control unit for max. 25 LED converters
 (max. 50mA/DC)

Dimension
 LxWxH=119x30x21 mm

3528003542



→ DALI 2

220 - 240V AC

PROGRAMMING
 REQUIRED

EXTERNAL
 POWER SUPPLY:
 DALI PS REQUIRED

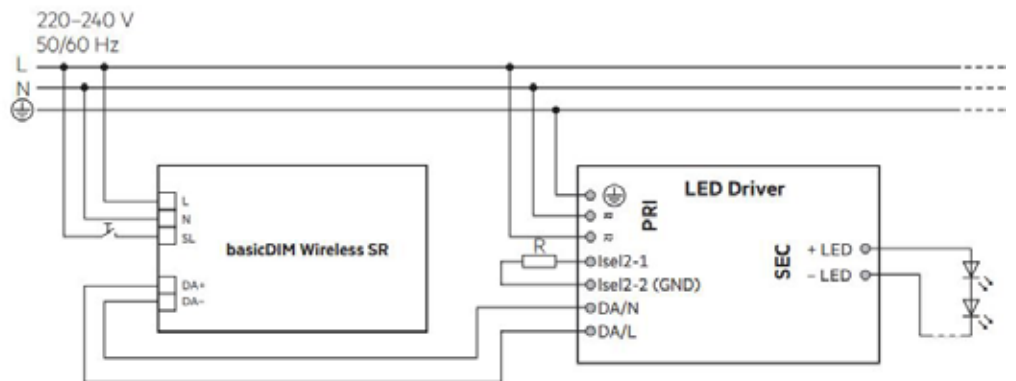

Zugentlastung |
 Strain relief set for basicDIM Wireless SR

(optional) 3528000881



CBU-TED

85-240 V / AC
Dimension
LxWxH=40,4x36,3x14 mm

420-CBU-TED

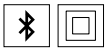

Bluetooth gesteuerter Dimmer für Phasen- und -abschnittsdimmung. Bis zu 150W Gesamtlast. Ideal geeignet zur Signalverstärkung.

Bluetooth controllable control gear for phase cut dimming. Up to 150 W total load. Ideally suited for signal amplification.

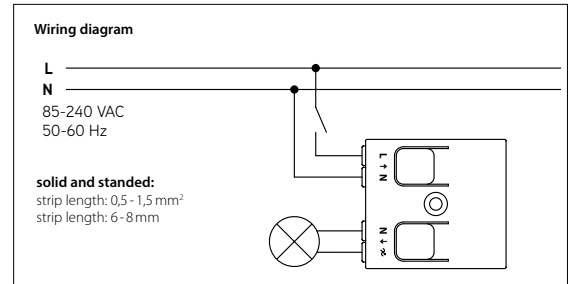

CBU-PWM4

BLUETOOTH 4.0, 12-24V DC

Bluetooth 4.0 PWM controllable dimmer. 1-4 channels, 12-24V DC, max. 6 A total.

Dimension
LxWxH=76,2x30x18 mm

420-CBU-PWM4



Wiring diagram, RGBW

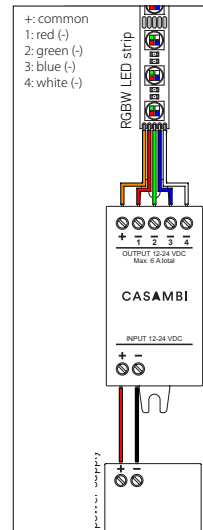

Wiring diagram, tunable white
(2 Channel warm-/coldwhite)

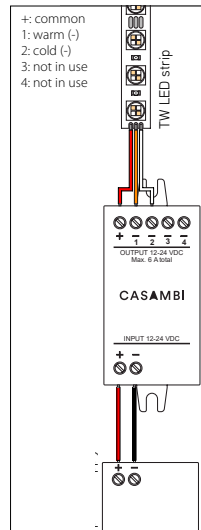

Wiring diagram, 1-4 separate channels

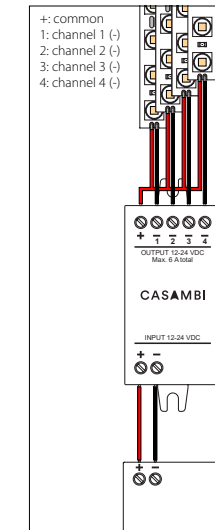

XPRESS

Dimension
LxWxH=90x90x12 mm

420-XPRESS-W white
420-XPRESS-B black



Wandschalter wireless. Batterie (CR2430 Lithium-Knopfzelle) inkludiert. Wandtaster wird magnetisch an einer Montageplatte befestigt, kann abgenommen und als Fernbedienung benutzt werden.

Wireless wall switch. Incl. battery (CR 2430 Lithium-ion). The switch is magnetically attached to a mounting plate. Can also be detached and used as a remote control.

EnOcean Casambi switch

Dimension
LxWxH=50x50x14 mm

428-E8221-A270
428-E8221-A280



Kabelloser, batterieloser Wandschalter. Konfiguration individuell durch App. Einfache Montage mit inkludiertem doppelseitigen Klebeband oder Verschraubung des Rahmens.

Wireless, battery-free switch. Configuration individual by app. Easy installation with included double-sided tape or screw joint.



MATTER

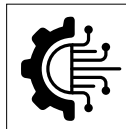

Technologie
Thread, kabellos

Technology
Thread, wireless



Anwendungsbereiche
Smart Home Systeme (Amazon Alexa, Apple HomeKit, Google Home und andere Matter-kompatible Systeme)

Application areas
Smart home systems (Amazon Alexa, Apple HomeKit, Google Home, and other Matter-compatible systems)

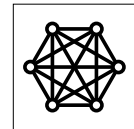

Komplexität
Einsteigerfreundlich

Complexity
Beginner-friendly

Matter-kompatible Steuerungen

Der herstellerübergreifende Verbindungsstandard für das Smart-Home - „Matter“ - fördert die Interoperabilität und sichere Kommunikation verschiedener smarten Ökosysteme und den Endgeräten von unterschiedlichen Herstellern.

Unabhängig davon, ob die Geräte über die Bridge des jeweiligen Herstellers oder über Sprachassistenten wie Amazon Echo oder Google Home verbunden sind: Der Matter-Standard schafft ein Smart Home-Ökosystem für die gemeinsame Nutzung digitaler Haustechnik und ermöglicht die einfache Steuerung.

PLANLICHT führt die Matter-kompatiblen Lichtsteuerungsprodukte von Tridonic (www.tridonic.com).

Matter-compatible controls

The cross-manufacturer connectivity standard for the smart home - „Matter“ - promotes interoperability and secure communication between various smart ecosystems and devices from different manufacturers. Whether the devices are connected through the respective manufacturer's bridge or via voice assistants like Amazon Echo or Google Home, the Matter standard creates a smart home ecosystem for the shared use of digital home technology, enabling easy control.

PLANLICHT offers Matter-compatible lighting control products from Tridonic (www.tridonic.com).



© 2023 Tridonic. All rights reserved.

Wireless Module MTR

IPv6 Thread, 230V/AC
 Control unit for max. 5 LED converters
 (max. 10mA/DC)
 Only for Broadcast DT6 applications

Dimension
 LxWxH=80,7x30x15,3 mm

3528004482



- DALI 2
- 220 - 240V AC

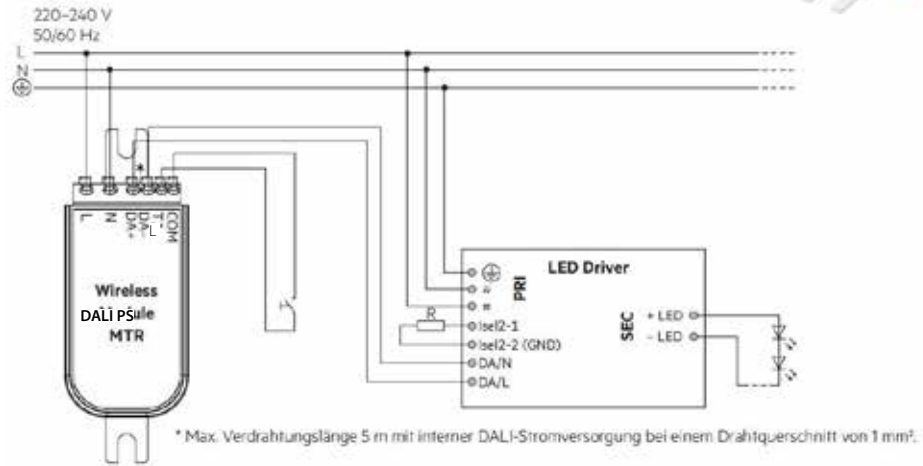

Wireless Module Passive MTR

IPv6 Thread
 Passive DALI-2 control unit without
 integrated DALI power supply
 Only for Broadcast DT6 applications
 Current consumption 4mA
 Also usable as push-button interface

Dimension
 LxWxH=80,7x30x15,3 mm

3528004483



- DALI 2
- 220 - 240V AC

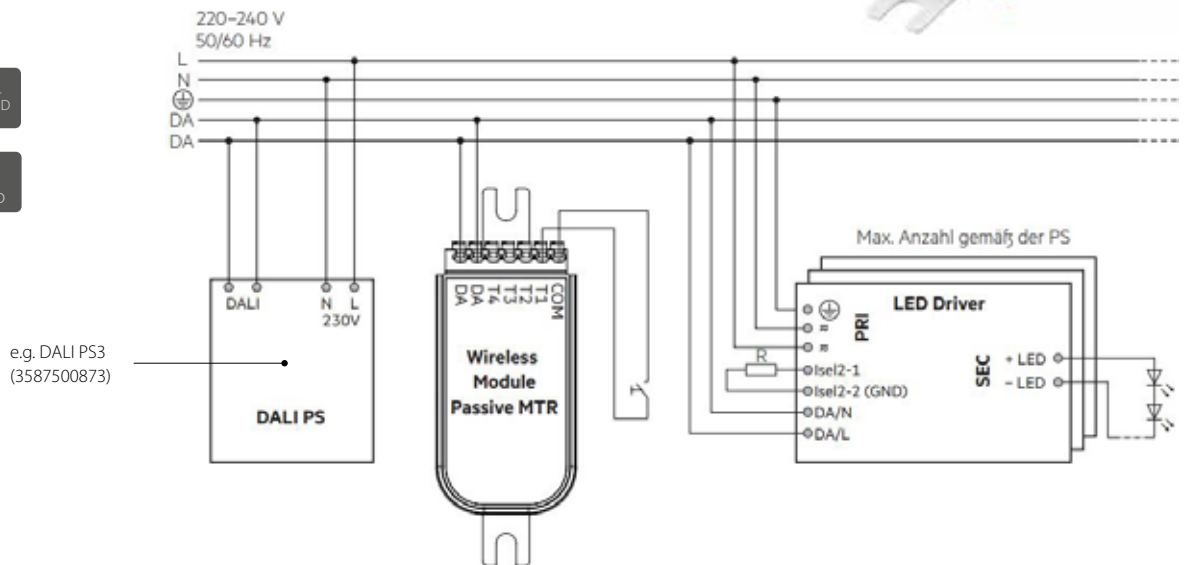

CONTROLS | MATTER

Wireless Module SR MTR

IPv6 Thread, 230V/AC
 Control unit for max. 25 LED converters
 (max. 50mA/DC)
 Only for Broadcast DT6 applications

Dimension
 LxWxH=119x30x21 mm

3528004484



→ DALI 2
 220-240V AC

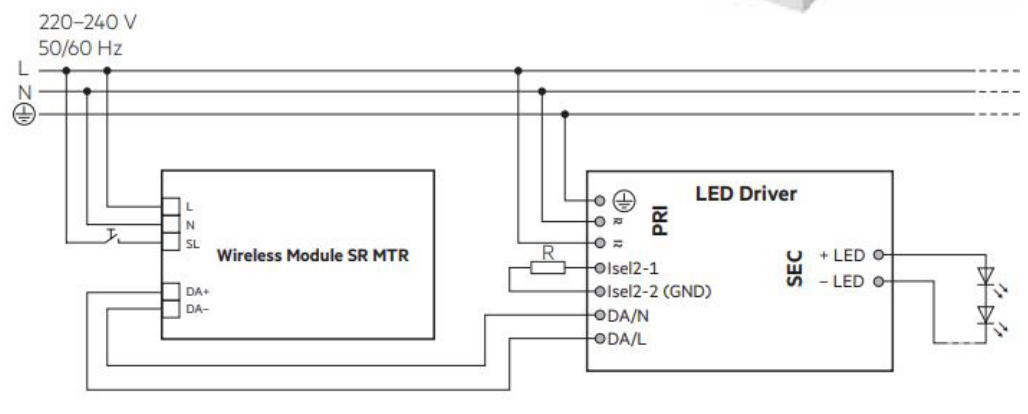

Zugentlastung |
 Strain relief set for Wireless Module SR MTR

(optional) 3528000881



BETRIEBSGERÄTE | DRIVERS

LSC4W	45H-LSC4W350LRP-UNI	90-264V/AC	1-3,3W	350mA/DC	2,7-9,5V/DC	49x27,2x20mm
LSC4W	45H-LSC4W500LRP-UNI	90-264V/AC	1,4-3,2W	500mA/DC	2,7-6,5V/DC	49x27,2x20mm
LSC7W	45H-LSC7W500LRP	198-264V/AC	3,3-6,5W	500mA/DC	6,5-13V/DC	49x27,2x20mm
LSC4W	45H-LSC4W700LRP-UNI	90-264V/AC	1,9-3,1W	700mA/DC	2,7-4,5V/DC	49x27,2x20mm
LSC7W	45H-LSC7W700LRP	198-264V/AC	4,2-7W	700mA/DC	6-10V/DC	49x27,2x20mm



LSC3W	45H-LSC3W350LR-ZU	90-264V/AC	1-3,5W	350mA/DC	2,7-10V/DC	65x29x18mm
LSC3W	45H-LSC3W500LR-ZU	90-264V/AC	1,4-3,5W	500mA/DC	2,7-7V/DC	65x29x18mm
LSC3W	45H-LSC3W700LR-ZU	90-264V/AC	1,9-2,8W	700mA/DC	2,7-4V/DC	65x29x18mm



PHASE-CUT

CC6W	427-CC6W350TR	198-264V AC	4,55-7,35W	350mA/DC	13-21V/DC	38x30x20mm
CC10W	427-CC10W500TR	198-264V AC	6,5-10W	500mA/DC	13-20V/DC	58,2x36x20mm



MP15 HPFU	448-127710	90-264V/AC	max. 2,5W bis max. 15W	60-360mA/DC	2-41,5V/DC	115x34x19mm
-----------	-------------------	------------	------------------------	-------------	------------	-------------

Ausgangstrom: 60-360mA/DC in 20mA Schritten per dipswitch einstellbar
 Output current: 60-360mA/DC adjustable in 20mA steps via dipswitch



LC8W fixC SR SNC2	3528003343	198-264V/AC	4,9-7,6W	180mA/DC	27-42V/DC	101,5x49x29mm
LC10W fixC SR SNC2	3528003344	198-264V/AC	6,8-10,5W	250mA/DC	27-42V/DC	101,5x49x29mm
LC7W fixC SR SNC2	3528003348	198-264V/AC	1,1-7W	350mA/DC	3-20V/DC	101,5x49x29mm
LC15W fixC SR SNC2	3528003345	198-264V/AC	9,5-14,7W	350mA/DC	27-42V/DC	101,5x49x29mm
LC21W fixC SR SNC2	3528003346	198-264V/AC	13,5-21W	500mA/DC	27-42V/DC	101,5x49x29mm



PHASE CUT

Mini Jolly 250-900 mA	448-125400	99-264V/AC	max. 18W	350mA/DC	15-50V/DC	110,4x52x22mm
			max. 20W	500mA/DC	5-40V/DC	
			max. 20W	700mA/DC	3-29V/DC	
			max. 20W	900mA/DC	3-23V/DC	
			max. 10W		12V/DC	
			max. 20W		24V/DC	



1-10V PUSH DIM

Stromeinstellung per Dipswitch |
 Current setting via dip switch

DRIVERS | CC CONVERTER

SR1



Inklusive Zugentlastung-Standard.
Including strain relief standard.

SR2



Primärseitig mit doppelter Klemme zum Durchschleifen.
Primary side with double terminal for looping through.

LC 20 Mini	423-5941005-SR1	max. 20W	176-264V/AC 176-280V/DC	150-500 mA/DC	10-42V/DC	173x43x31mm
LC 28 Mini	423-5928005-SR1	max. 28W	176-264V/AC 176-280V/DC	500-700 mA/DC	28-40V/DC	173x43x31mm
LC 43 Mini	423-5945005-SR1	max. 43W	176-264V/AC 176-280V/DC	150-500 mA/DC	9-48V/DC	173x43x31mm
LC 20 Mini	423-5941005-SR2	max. 20W	176-264V/AC 176-280V/DC	150-500 mA/DC	10-42V/DC	222x56x31mm
LC 28 Mini	423-5928005-SR2	max. 28W	176-264V/AC 176-280V/DC	500-700 mA/DC	28-40V/DC	222x56x31mm
LC 43 Mini	423-5945005-SR2	max. 43W	176-264V/AC 176-280V/DC	150-500 mA/DC	9-48V/DC	222x56x31mm

Bestromung per Dipswitch einstellbar.
Power supply adjustable via dip switch.

LC 62/700-1400/57 flex SC SNC4	3587501125	max. 62W	198-264V AC	750-1050 mA/DC bei 1400mA/DC	27-57V/DC max. 44V/DC	115 x 43 x 30 mm
-----------------------------------	-------------------	----------	-------------	---------------------------------	--------------------------	------------------

Bestromung per Dipswitch in 100mA-Schritten einstellbar.
Power supply adjustable in 100mA increments via dip switch.



175 x 43 x 30 mm mit 2 x Zugentlastung 3528001699 als Zubehör erhältlich!
175 x 43 x 30 mm with 2 x strain relief 3528001699 available as an accessory!

LC 20W NF SR EXC3	100-1050mA	3587500961	198-264V/AC 176-270V/DC	1,5-4,4W	100 mA/DC	15-44V/DC	120x51 x 29,2 mm
				2-11W	250 mA/DC	7-44V/DC	
				2,5-15W	350 mA/DC	7-44V/DC	
				3,5-18W	500 mA/DC	7-36V/DC	
				5-18W	700 mA/DC	7-25,8V/DC	
				6,3-18W	900 mA/DC	7-20V/DC	
				7,5-18W	1050 mA/DC	7-17V/DC	
LC 27W NF SR EXC3	100-500mA	3587500962	198-264V/AC 176-270V/DC	2,7-5,4W	100 mA/DC	27-54V/DC	160x82 x 34 mm
				9,5-18,9W	350 mA/DC	27-54V/DC	
				13,5-27W	500 mA/DC	27-54V/DC	
LC 45W NF SR EXC3	500-1050mA	3587500963	198-264V/AC 176-270V/DC	13,5-27W	500 mA/DC	27-54V/DC	160x82 x 34 mm
				18,9-37,8W	700 mA/DC	27-54V/DC	
				21,6-43,2W	800 mA/DC	27-54V/DC	
				28,5-45W	1050 mA/DC	27-42,9V/DC	



Stromeinstellung bei Bestellung angeben (zum Beispiel: 3587500963-0800MA)
Specify current setting when ordering (for Example: 3587500963-0800MA)

LC 20W o4a NF SR EXC3	100-1050mA	3587500921	198-264V/AC 176-270V/DC	1,5-4,4W	100mA/DC	15-44V/DC	120x51x29,2mm
				2-11W	250mA/DC	7-44V/DC	
				2,5-15W	350mA/DC	7-44V/DC	
				3,5-18W	500mA/DC	7-36V/DC	
				5-18W	700mA/DC	7-25,8V/DC	
				6,3-18W	900mA/DC	7-20V/DC	
				7,5-18W	1050mA/DC	7-17V/DC	



LC 27W o4a NF SR EXC3	100-500mA	3587500922	198-264V/AC 176-270V/DC	2,7-5,4W	100mA/DC	27-54V/DC	160x82x34mm
				9,5-18,9W	350mA/DC	27-54V/DC	
				13,5-27W	500mA/DC	27-54V/DC	

LC 45W o4a NF SR EXC3	100-1050mA	3587500923	198-264V/AC 176-270V/DC	13,5-27W	500mA/DC	27-54V/DC	160x82x34mm
				18,9-37,8W	700mA/DC	27-54V/DC	
				21,6-43,2W	800mA/DC	27-54V/DC	
				28,5-45W	1050mA/DC	27-42,9V/DC	



Stromeinstellung bei Bestellung angeben (zum Beispiel: 3587500923-0800MA)
Specify current setting when ordering (for Example: 3587500923-0800MA)

IPR2	448-152014/350	99-264V/AC 170-276V/DC	1-17W	350mA/DC	5-49V/DC	121,5x53,5x26mm
IPR2	448-152014/500		1-24W	500mA/DC	5-49V/DC	121,5x53,5x26mm
IPR2	448-152014/700		1-30W	700mA/DC	5-43V/DC	121,5x53,5x26mm



IPR3 Flat 38 DALI NFC	448-152040	99-264V/AC	1,5-38W	150-1050mA/DC	10-54V/DC	127x47x28mm
-----------------------	------------	------------	---------	---------------	-----------	-------------



basicDIM Wireless - CASAMBI ready

LC 10W bdW SC PRE2 IP20	3528002411	198-264V/AC 176-270V/DC	2,25-10W	150-400mA/DC	15-40V/DC	130x43x30mm
LC 17W bdW SC PRE2 IP20	3528002412		3,75-17W	250-700mA/DC	15-50V/DC	130x43x30mm
LC 25W bdW SC PRE2 IP20	3528002413		7-25W	350-1050mA/DC	20-50V/DC	130x43x30mm
LC 45W bdW SC PRE2 IP20	3528002414		12,5-45W	500-1400mA/DC	25-50V/DC	150x43x30mm



Stromeinstellung über LEDset Widerstand
Current setting via LEDset resistor

DRIVERS | CV- 24V CONVERTER

PMR24 24V	45A-LKV024-008RU	190-265V/AC	24V/DC	max. 8,4W	ø 53 x 19 mm
-----------	-------------------------	-------------	--------	-----------	--------------



Slim 24V	45AA40SL243500B	100-265 V/AC	24V/DC	max. 8,4W	114x22x19 mm
----------	------------------------	--------------	--------	-----------	--------------



SHT-MTL	439-VLM040E-24-T	220-240V/AC	24V/DC	max. 40W	199x20x20 mm
SHT-MTL	439-VLM060E-24-T	220-240V/AC	24V/DC	max. 60W	199x20x20 mm
SHT-MTL	439-VLM100E-24-T	220-240V/AC	24V/DC	max. 100W	209x26x20 mm



LPH-18 24V	440-LPH-18-24	180-264V/AC	24V/DC	max. 18W	140x30x22 mm
LPV-35 24V	440-LPV-35-24	90-264V/AC	24V/DC	max. 35W	148x40x30 mm
LPV-60 24V	440-LPV-60-24	90-264V/AC	24V/DC	max. 60W	163x43x32 mm
LPV-100 24V	440-LPV-100-24	90-264V/AC	24V/DC	max. 100W	190x52x37 mm



IP67

LC 24V SC SNC2	3587501054	198-264V/AC	24V/DC	max. 35W	142x43x30 mm
LC 24V SC SNC2	3587501055	198-264V/AC	24V/DC	max. 60W	225x43x30 mm
LC 24V SC SNC2	3587501056	198-264V/AC	24V/DC	max. 100W	295x43x30 mm
LC 24V SC SNC2	3587501057	198-264V/AC	24V/DC	max. 200W	325x43x30 mm



ELG-75	440-ELG-75-24DA	100-305V/AC 142-431 V/DC	24V/DC	max. 75W	180x63x35,5 mm
ELG-150	440-ELG-150-24DA	100-305V/AC 142-431 V/DC	24V/DC	max. 150W	219x63x35,5 mm
ELG-240	440-ELG-240-24DA	100-305V/AC 142-431 V/DC	24V/DC	max. 240W	244x71x35,5 mm



ELG-75

ELG-250

ELG-240





DALI IP67

OPTOTRONIC OT LED IP66 24V	540OT060P	198-264V/AC 176-250V/DC	24V/DC	max. 60W	205 x 43 x 26 mm	
OPTOTRONIC OT LED IP67 24V	540OT130P	198-264V/AC 176-250V/DC	24V/DC	max. 130W	220 x 63 x 37 mm	
OPTOTRONIC OT LED IP67 24V	540OT250P	198-264V/AC 176-250V/DC	24V/DC	max. 250W	265 x 68 x 40 mm	



IP66 IP67

OPTOTRONIC OT LED IP66 24V	540OT060P-AN	198-264V/AC 176-250V/DC	24V/DC	max. 60W	205 x 43 x 26 mm	
OPTOTRONIC OT LED IP67 24V	540OT130P-AN	198-264V/AC 176-250V/DC	24V/DC	max. 130W	220 x 63 x 37 mm	
OPTOTRONIC OT LED IP67 24V	540OT250P-AN	198-264V/AC 176-250V/DC	24V/DC	max. 250W	265 x 68 x 40 mm	



1-10V IP66 IP67

DC 45W MD 24V	448-127913	220-240V/AC	24V/DC	max. 45W	180 x 60 x 35 mm
---------------	-------------------	-------------	--------	----------	------------------

PHASE CUT



DC 80W MD 24V	448-127915	220-240V/AC	24V/DC	max. 80W	200 x 70 x 46 mm
---------------	-------------------	-------------	--------	----------	------------------

PHASE CUT IP66



LC 18W 24W one4all NF SC EXC2	3528004429	198-264V/AC 176-280V/DC	24V/DC	max. 18W	175 x 43 x 30 mm
LC 35W 24W one4all NF SC EXC2	3528004430	198-264V/AC 176-280V/DC	24V/DC	max. 35W	195 x 43 x 30 mm
LC 60W 24W one4all NF SC EXC2	3528004431	198-264V/AC 176-280V/DC	24V/DC	max. 60W	225 x 43 x 30 mm
LC 100W 24W one4all NF SC EXC2	3528004432	198-264V/AC 176-280V/DC	24V/DC	max. 100W	295 x 43 x 30 mm
LC 200W 24W one4all NF SC EXC2	3528004433	198-264V/AC 176-280V/DC	24V/DC	max. 200W	325 x 43 x 30 mm

DALI SWITCH DIM

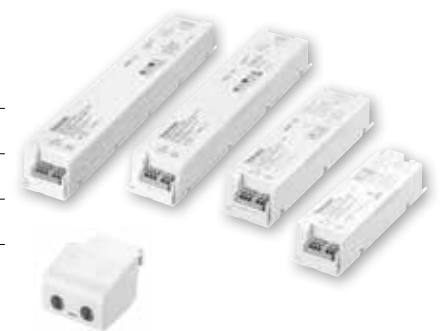

DRIVERS | CV- 24V CONVERTER

basicDIM Wireless - CASAMBI ready

LC 35W bdW SC PRE2 IP20	3528002677
LC 60W bdW SC PRE2 IP20	3528002674
LC 100W bdW SC PRE2 IP20	3528002675
LC 150W bdW SC PRE2 IP20	3528002678

198-264V/AC
176-270V/DC

24V/DC	max. 35W	195x43x30,2 mm
24V/DC	max. 60W	225x43x30,2 mm
24V/DC	max. 100W	295x43x29,8 mm
24V/DC	max. 150W	325x43x29,8 mm



matter

LC 35W MTR SC PRE2 IP20	3528004489
LC 60W MTR SC PRE2 IP20	3528004490
LC 100W MTR SC PRE2 IP20	3528004491
LC 150W MTR SC PRE2 IP20	3528004492

198-264V/AC
176-280V/DC

24V/DC	max. 35W	195x43x30,2 mm
24V/DC	max. 60W	225x43x30,2 mm
24V/DC	max. 100W	295x43x29,8 mm
24V/DC	max. 150W	325x43x29,8 mm



LPV-60	440-LPV-60-48	90-264V/AC 127-370V/DC	48V/DC	max. 60W	163x43x32mm
--------	----------------------	---------------------------	--------	----------	-------------



IP67

LCA one4all NF SC EXC48V	3528003533	198-264V/AC 176-280V/DC	48V/DC	max. 35W	195x43x30mm
LCA one4all NF SC EXC48V	3528003534		48V/DC	max. 60W	195x43x30mm
LCA one4all NF SC EXC48V	3528003535		48V/DC	max. 100W	225x43x30mm
LCA one4all NF SC EXC48V	3528003536		48V/DC	max. 200W	325x43x30mm



DALI

ELG 48V DALI IP67	440-ELG-100-48DA	100-305V/AC 142-431V/DC	48V/DC	max. 100W	199x63x35,5mm
ELG 48V DALI IP67	440-ELG-240-48DA		48V/DC	max. 240W	244x71x35,5mm



IP67 DALI











LCA SC SNC 48V nicht dimmbar	3587501096	198-264V/AC	48V/DC	max. 100W	295x43x30mm
------------------------------	-------------------	-------------	--------	-----------	-------------



KOMPONENTEN FÜR SYSTEME | COMPONENTS FOR SYSTEMS



COMPONENTS NON-DIM

01 SURFACE-MOUNT TRACK

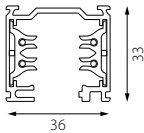
	1000 mm	676001AL
	1000 mm	676001SW
	1000 mm	676001WS
	2000 mm	676002AL
	2000 mm	676002SW
	2000 mm	676002WS
	3000 mm	676003AL
	3000 mm	676003SW
	3000 mm	676003WS
	4000 mm	676004AL
	4000 mm	676004SW
	4000 mm	676004WS



02 END CAP

	676011SI
	676011SW
	676011WS

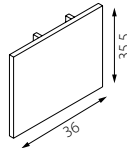

03 LINEAR CONDUCTIVE CONNECTOR

	676006SW
	676006WS

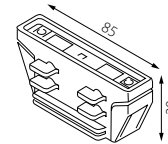

leitend
conductive

04 CLAMP

	676013
---	--------

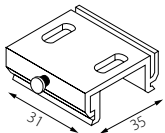

05 LINEAR NON-CONDUCTIVE CONNECTOR

	676023
---	--------

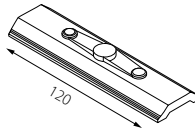

06 CENTRAL POWER FEED

	676007SI
	676007SW
	676007WS

07 POWER END FEED

	676004LSI
	676004LSW
	676004LWS

08 POWER END FEED

	676004RSI
	676004RSW
	676004RWS

09 COVER

	1000 mm	676019SW
	1000 mm	676019WS



10 X-CONNECTOR

	676022SI
	676022SW
	676022WS

11 FLEXIBLE CONNECTOR

	676010SI
	676010SW
	676010WS

12 T-CONNECTOR

	676012LSI
	676012LSW
	676012LWS
	676012RSI
	676012RSW
	676012RWS

13 L-CONNECTOR

	676008LSI
	676008LSW
	676008LWS
	676008RSI
	676008RSW
	676008RWS

14 CLIP CADDY T-RAIL

	SB0760
---	--------

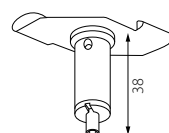

26 mm mit Schnellspanner,
für Stahlseil 1 mm.
26 mm with quick release,
for steel cable 1 mm.

15 CEILING ATTACHMENT WITH QUICK RELEASE

	26 mm, with quick release for steel rope 1 mm	B57100
---	--	--------

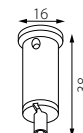

für Stahlseil 1 mm
for steel rope 1 mm

16 SUSPENSION ROPE

- 2000 mm
- 2000 mm
- 6000 mm
- 6000 mm

- 676014SW
- 676014WS
- 676016SW
- 676016WS

für Deckenhaken
for ceiling hooks

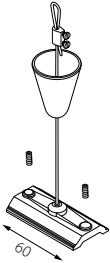

17 WITH CEILING MOUNTS

- 2000 mm
- 6000 mm

- 676026WS
- 676026WS-6

Inklusive Schnellspanner unten.
Include the quick release below.

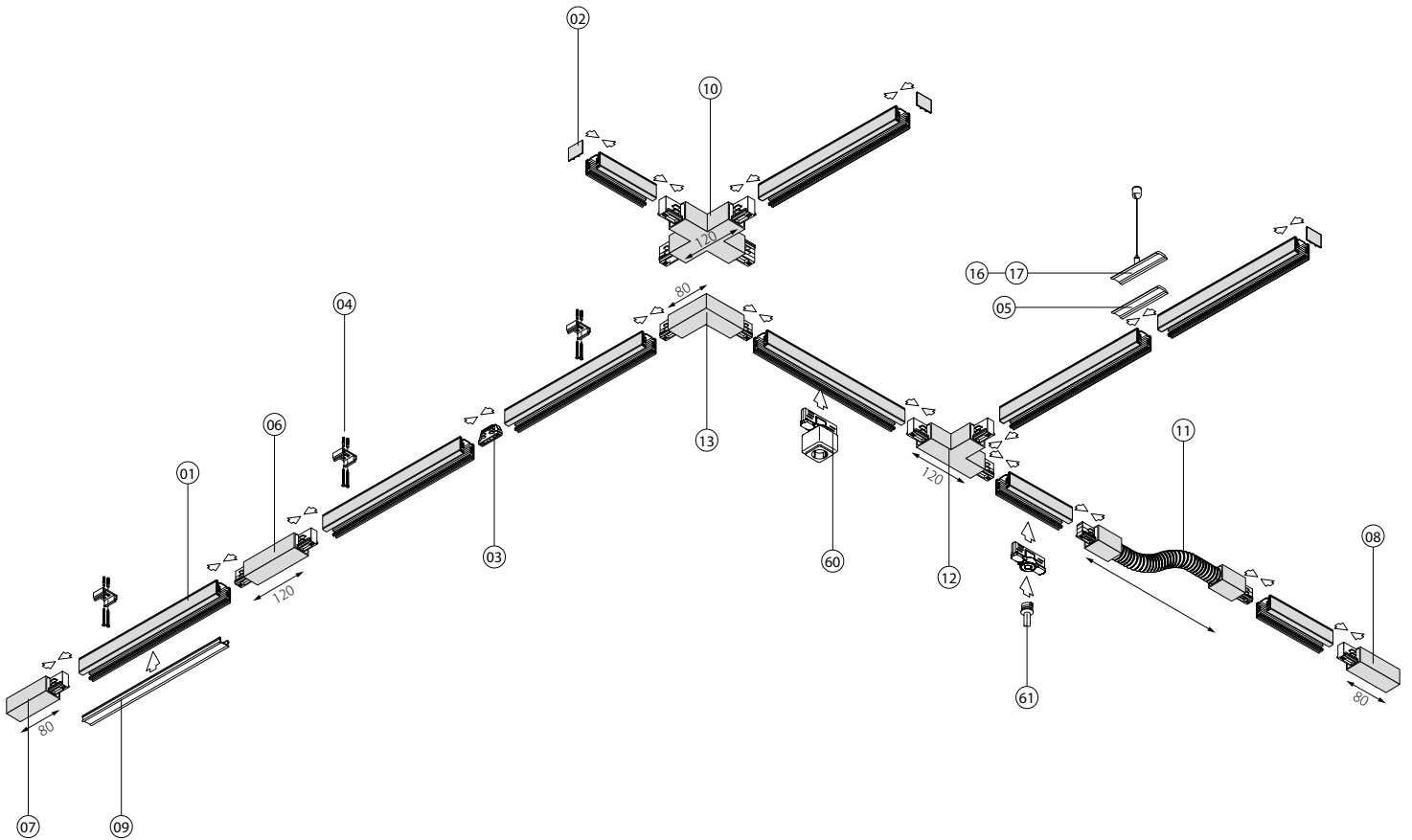
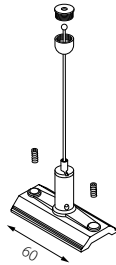













- ← left
- right
- inside
- outside
- silver
- black
- white
- chrome





COMPONENTS NON-DIM

21 RECESSED TRACK

	1000 mm	679001AL
	1000 mm	679001SW
	1000 mm	679001WS
	2000 mm	679002AL
	2000 mm	679002SW
	2000 mm	679002WS
	3000 mm	679003AL
	3000 mm	679003SW
	3000 mm	679003WS
	4000 mm	679004AL
	4000 mm	679004SW
	4000 mm	679004WS

22 END CAP

	677659100W20
	677659100W30
	677659100W31

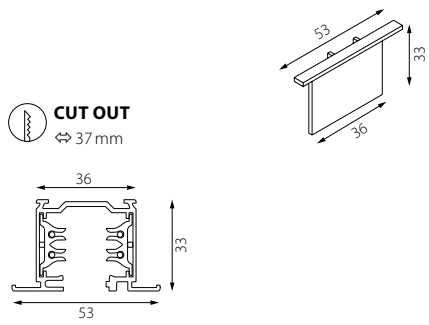

CUT OUT
↕ 37 mm





23 CENTRAL POWER FEED

	679007SI
	679007SW
	679007WS

24 POWER END FEED

	679004LSI
	679004LSW
	679004LWS
	679004RSI
	679004RSW
	679004RWS

03 LINEAR CONDUCTIVE CONNECTOR

	676006SW
	676006WS

leitend
conductive

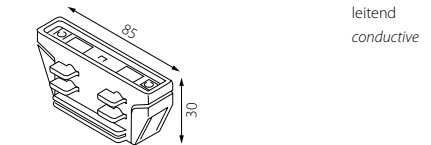

05 LINEAR NON-CONDUCTIVE CONNECTOR

	676023
---	--------

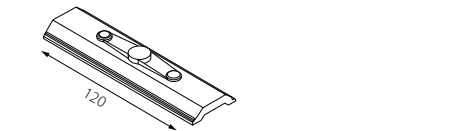

09 COVER

	1000 mm	676019SW
	1000 mm	676019WS



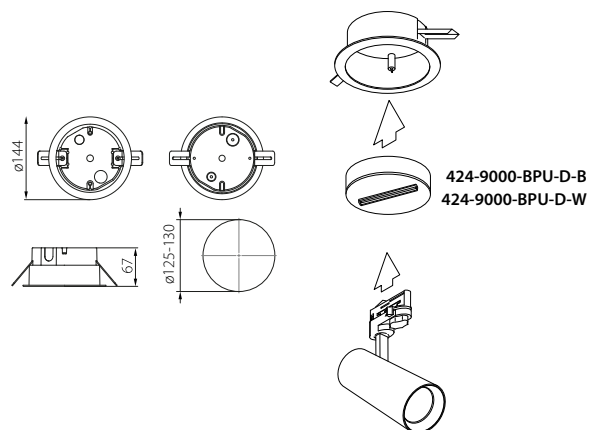
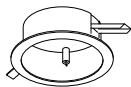

10 RECESSED HOUSING FOR MONOPOINT

	424-9000-BRU-B
	424-9000-BRU-W

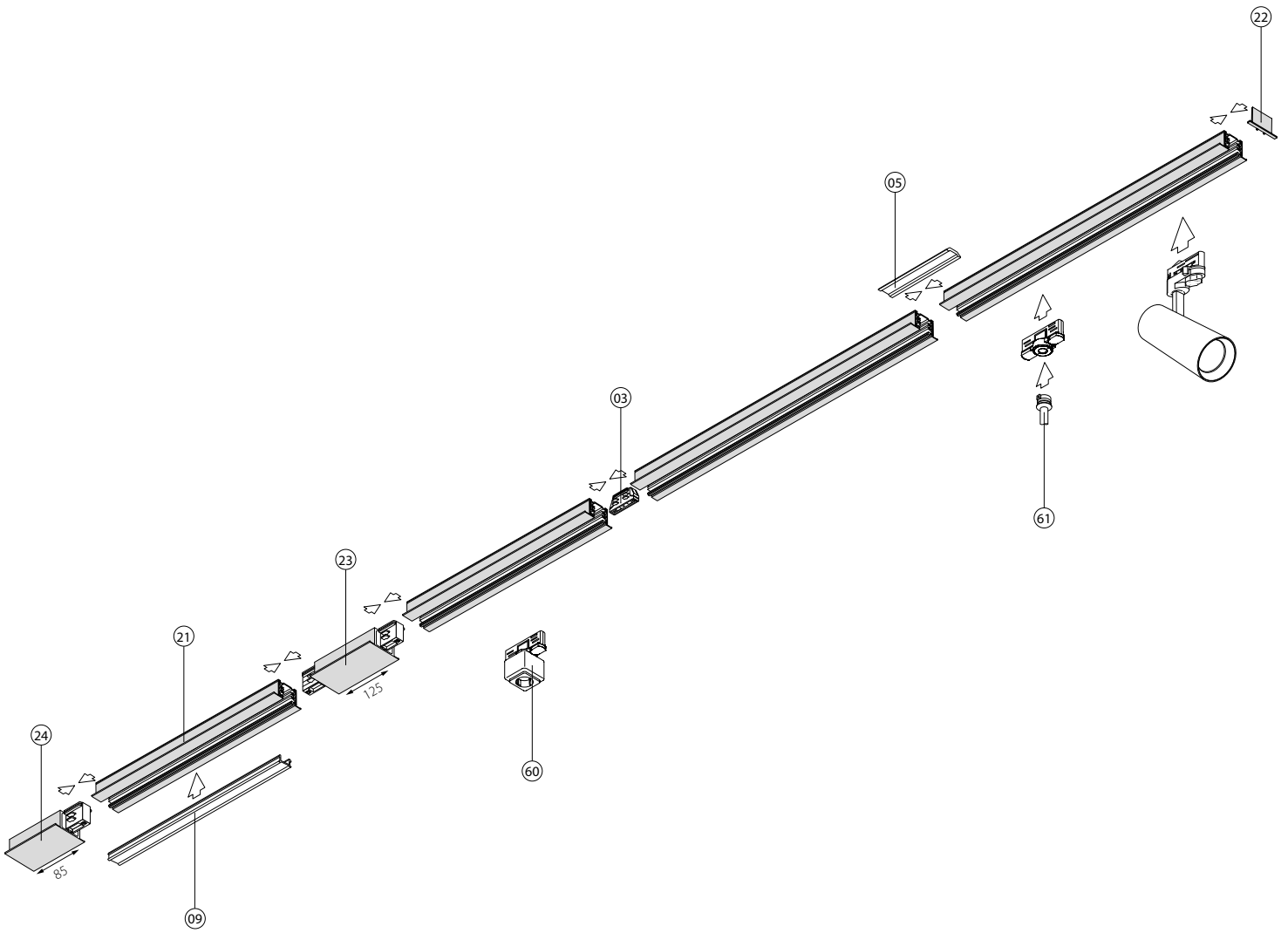
Adapter für Basis 9000-BPU
Adapter for base 9000-BPU

















-  left
-  right
-  silver
-  white
-  black

COMPONENTS Stucchi DALI OneTrack

01 SURFACE MOUNTED TRACK

	1000 mm	424-9000A-1-G-ST
	1000 mm	424-9000A-1-B-ST
	1000 mm	424-9000A-1-W-ST
	2000 mm	424-9000A-2-G-ST
	2000 mm	424-9000A-2-B-ST
	2000 mm	424-9000A-2-W-ST
	3000 mm	424-9000A-3-G-ST
	3000 mm	424-9000A-3-B-ST
	3000 mm	424-9000A-3-W-ST
	4000 mm	424-9000A-4-G-ST
	4000 mm	424-9000A-4-B-ST
	4000 mm	424-9000A-4-W-ST

02 CUTTING TOOL

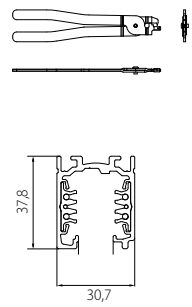

424-S-9000-T

Schneidewerkzeug für Kupfer.
Cutting tool for track copper.
Outil de coupe pour les cuivre.



37,8
30,7





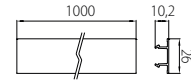

03 COVER

	424-9000-GP-G
	424-9000-GP-B
	424-9000-GP-W

Zusätzlicher Abdeckstreifen für Schiene.
Additional cover strip for track.
Bande de recouvrement supplémentaire pour le rail.



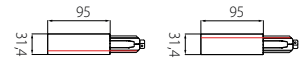

04 POWER END FEED

	424-9001-G
	424-9001-B
	424-9001-W
	424-9002-G
	424-9002-B
	424-9002-W



95
31,4

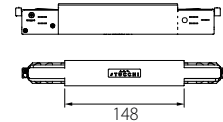

05 MIDDLE POWER FEED

	424-9010-G
	424-9010-B
	424-9010-W



148



06 END CAP

	424-9004-G
	424-9004-B
	424-9004-W

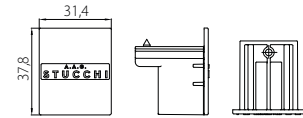
Endkappe mit Feststellschraube.
End cap with locking screw.
Capuchon d'extrémité avec vis de blocage.



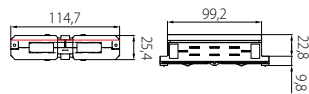

07 LINEAR CONDUCTIVE CONNECTOR

	424-9003-G
	424-9003-B
	424-9003-W



114,7
99,2
25,4
22,8
9,8





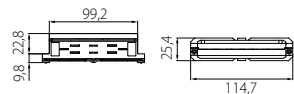

08 LINEAR NON-CONDUCTIVE CONNECTOR

	424-9003-G-M
	424-9003-B-M
	424-9003-W-M



99,2
9,8
22,8
25,4
114,7





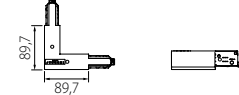

09 L-CONNECTOR

	424-9011-G
	424-9011-B
	424-9011-W
	424-9012-G
	424-9012-B
	424-9012-W





89,7
89,7

10 T-CONNECTOR

	424-9013-G
	424-9013-B
	424-9013-W
	424-9014-G
	424-9014-B
	424-9014-W
	424-9015-G
	424-9015-B
	424-9015-W
	424-9016-G
	424-9016-B
	424-9016-W

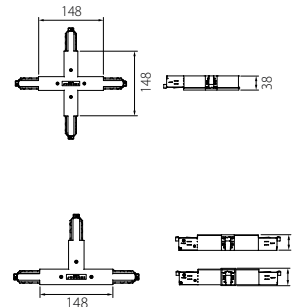

11 X-CONNECTOR

	424-9017-G
	424-9017-B
	424-9017-W



148
148
38
148
42

12 FLEXIBLE CONNECTOR

	424-9018-G
	424-9018-B
	424-9018-W

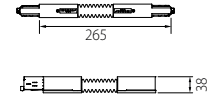

265
38

13 SUSPENSION KIT

- 3000 mm **424-9000-KIT8-3**
- 3000 mm **424-9000-KIT8-3-B**
- 3000 mm **424-9000-KIT8-3-W**

Inklusive Deckenbefestigung mit rundem Kopf, Stahlseil ø1,5mm mit kugelförmigem Ende, Bügel mit Schnellspanner.
 Includes round head ceiling attachment, steel cable ø1.5mm with spherical end, bracket with quick release.
 Comprend une fixation au plafond à tête ronde, un câble en acier ø1,5mm avec extrémité sphérique, un support avec libération rapide.



14 CEILING BRACKET

- 424-S-9000-131**
- 424-S-9000-131-B**
- 424-S-9000-131-W**

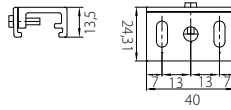

15 PENDING SUSPENSION

- 424-S-9000-P6-SB**
- 424-S-9000-P6-SW**

Beinhaltet Deckenhalterung, Baldachin (ø100mm), M13 Gewindestange (L=1200mm) mit Gegenmutter.
 Includes ceiling bracket, canopy (ø100mm), M13 threaded stem (L=1200mm) with counter-nut.
 Comprend un support de plafond, canopée (ø100mm), une tige filetée M13 (L=1200mm) avec contre-écrou.

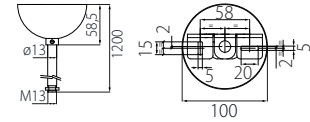

16 RAIL CONNECTOR

- 424-S-9000-332-SV**
- 424-S-9000-332-SV-B**
- 424-S-9000-332-SV-W**

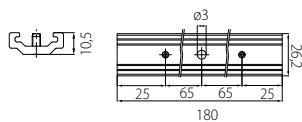

17 M13 CLIP FOR PENDING SUSPENSION

- 424-S-9000-322-M13-B**
- 424-S-9000-322-M13-W**

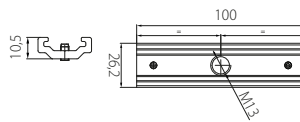

18 MONOPOINT

- 424-9000-BPU-D-B**
- 424-9000-BPU-D-W**

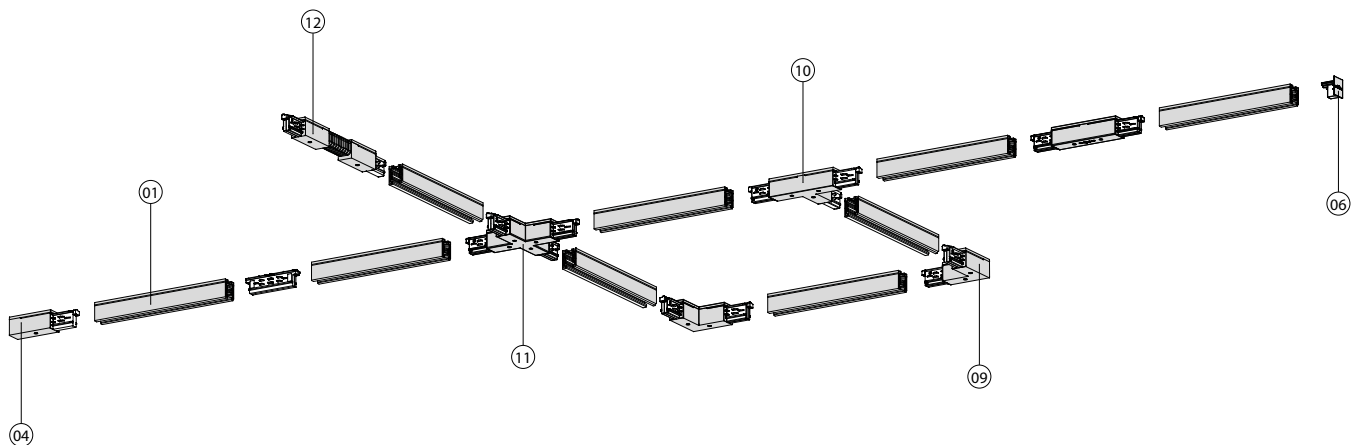
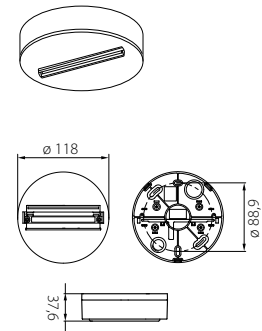



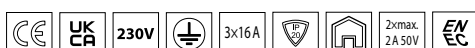

- inside
- outside
- left
- right
- grey
- black
- white
- zinc



COMPONENTS Stucchi DALI OneTrack

18 RECESSED TRACK

	1000 mm	424-9000-1-B-R
	1000 mm	424-9000-1-W-R
	2000 mm	424-9000-2-B-R
	2000 mm	424-9000-2-W-R
	3000 mm	424-9000-3-B-R
	3000 mm	424-9000-3-W-R



19 CUTTING TOOL

424-S-9000-T

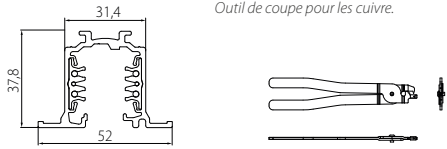
Schneidewerkzeug für Kupfer.
Cutting tool for track copper.
Outil de coupe pour les cuivre.





20 COVER

	424-9000-GP-B
	424-9000-GP-W

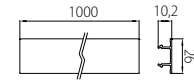
Zusätzlicher Abdeckstreifen für Schiene.
Additional cover strip for track.
Bande de recouvrement supplémentaire pour le rail.



21 END CAP

	424-9004-R-B
	424-9004-R-W

Endkappe mit Feststellschraube.
End cap with locking screw.
Capuchon d'extrémité avec vis de blocage.

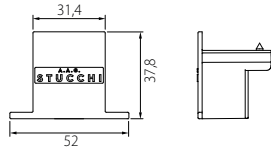

22 LINEAR CONDUCTIVE CONNECTOR

	424-9003-B
	424-9003-W

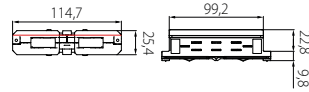

23 LINEAR NON-CONDUCTIVE CONNECTOR

	424-9003-B-M
	424-9003-W-M

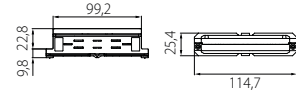

24 COVER FOR POWER END FEED

	424-S-9001-R-6-B
	424-S-9001-R-6-W

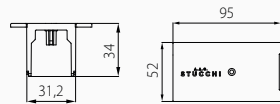

25 COVER FOR MIDDLE POWER FEED

	424-S-9010-R-6-B
	424-S-9010-R-6-W

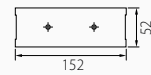

26 COVER FOR L-CONNECTOR

	424-S-9011-R-6-B
	424-S-9011-R-6-W

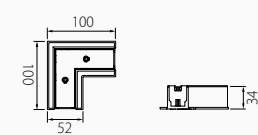

27 POWER END FEED

	424-9001-B
	424-9001-W
	424-9002-B
	424-9002-W

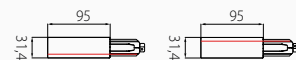

28 MIDDLE POWER FEED

	424-9010-B
	424-9010-W

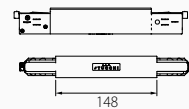

29 L-CONNECTOR

	424-9011-B
	424-9011-W

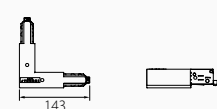





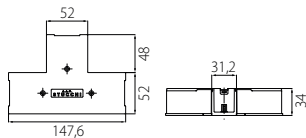







30 COVER FOR T-CONNECTOR

	424-S-9013-R-6-B
	424-S-9013-R-6-W
	424-S-9017-R-6-B
	424-S-9017-R-6-W



31 T-CONNECTOR

	424-9013-G		424-9015-G
	424-9013-B		424-9015-B
	424-9013-W		424-9015-W
	424-9014-G		424-9016-G
	424-9014-B		424-9016-B
	424-9014-W		424-9016-W

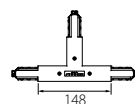

32 T-BRACKET

	424-S-9000-313-B
	424-S-9000-313-W
	424-S-9000-313

Kurzer T-Bügel für Aufhängungen.
Short T bracket for suspensions.
Support en T court pour les suspensions.

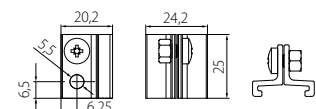

33 RAIL CONNECTOR



424-S-9000-332-SV-B

424-S-9000-332-SV-W

424-S-9000-332-SV

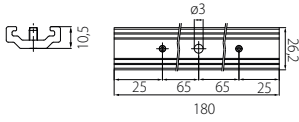

34 RECESSED HOUSING FOR MONOPOINT



424-9000-BRU-B

424-9000-BRU-W

Adapter für Basis 9000-BPU
Adapter for base 9000-BPU
Adaptateur pour la base 9000-BPU

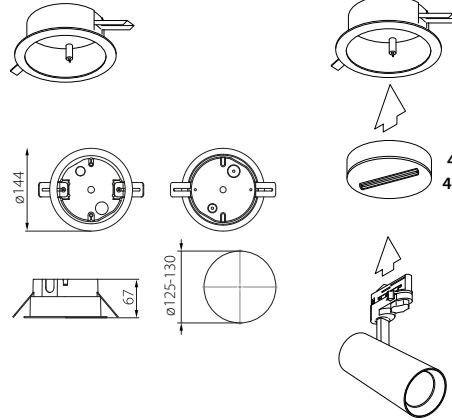

424-9000-BPU-D-B
424-9000-BPU-D-W

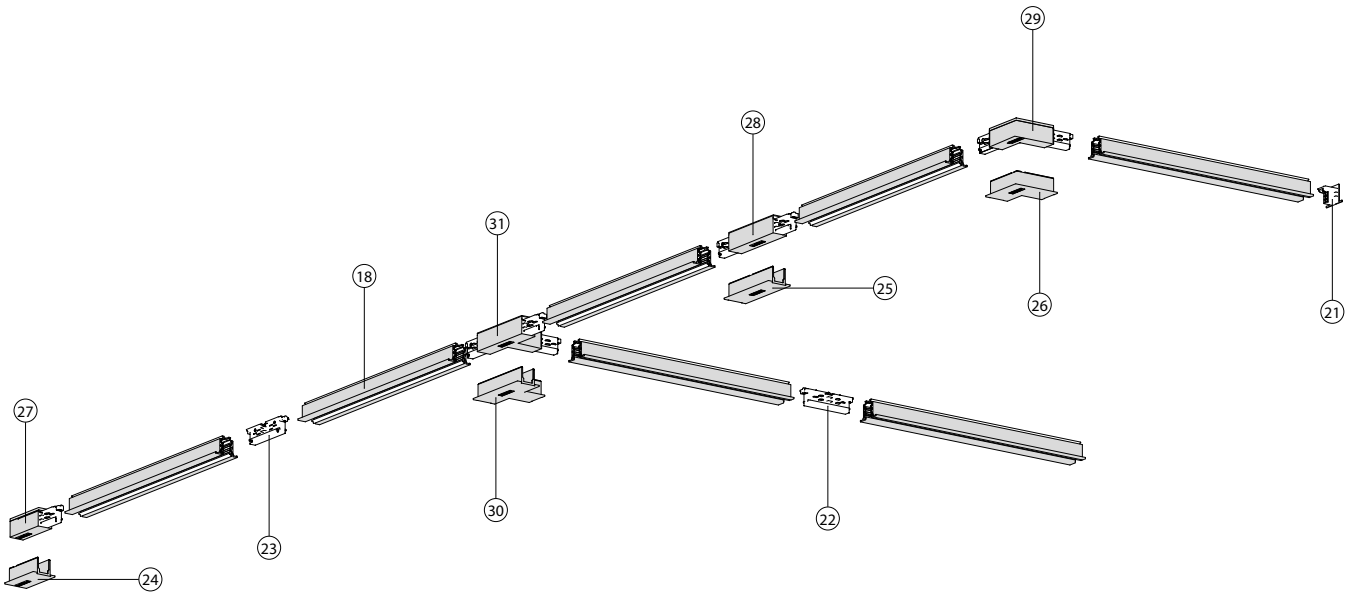

- left
- right
- black
- white
- zinc

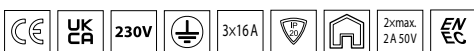

COMPONENTS - ADAPTERS

03 STUCCHI INSTALLATION TOOL



424-S-9009-T-INS

Einbauwerkzeug-Einsatz für Adapterverdrahtung.
Installation tool insert for adapter wiring.
Outil d'installation pour le câblage de l'adaptateur.

STUCCHI SUSPENSION HOOK



424-S-9000-H-B



424-S-9000-H-W

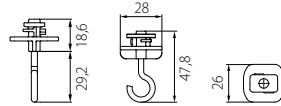

04 STUCCHI MOUNTING NIPPLE



424-S-9009-M10



424-S-9009-M13

M10 und M13 aus Aluminium, zur Aufnahme von Spots.
M10 and M13 made of aluminum, for holding spots.
M10 et M13 en aluminium, pour l'installation de spots.

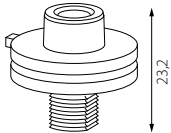

05 STUCCHI MOUNTING NIPPLE FOR CABLE



424-S-9009-BC-B



424-S-9009-BC-W

Für Mantelleitung. DALI-Mantelleitung, inkl. Zugentlastung aus Aluminium.

For sheathed cable. DALI sheathed cable, incl. strain relief made of aluminium.

Pour conducteur sous gaine. Gaine DALI avec dispositif de décharge de traction de câble en aluminium.

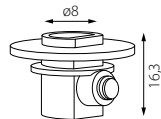

61 STUCCHI MOUNTING NIPPLE M10



424-S-9009-M10-FI



Nippel mit M10 Innengewinde für Adapter 9009, 9209, 9409.
Nipples with M10 internal thread for adapters 9009, 9209, 9409.
Embout avec filetage interne M10 pour adaptateurs 9009, 9209, 9409.

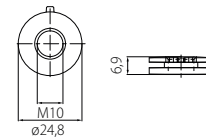

60 EUTRAC SCHUKO-ADAPTER



71990952

71990956

Für den Anschluss von Geräten der Schutzklasse I (System Schuko) bzw. universell einsetzbar für Geräteflachstecker Schutzklasse II, für Netzspannung 220-240V mit Sicherung 6,3 A, träge.

For the connection of devices of protection class I (System Schuko) or universally applicable for flat plugs of protection class II, for mains voltage 220-240V with fuse 6,3 A, slow.

Pour le raccordement d'appareils de classe de protection I (système Schuko / prise de type F) ou de prises plates d'appareils de classe 2. Pour tension de réseau 220-240 V, avec fusible temporisé 6,3 A.

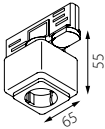

01 STUCCHI MULTI-DALI ADAPTER



424-9009-B

424-9009-W

Für Datenbusschiene, kompatibel mit: AAG-Stucchi mit Datenbus und Nordic/Global Track Pulse.

For data bus rail, compatible with: AAG-Stucchi with data bus and Nordic / Global Track Pulse.

Pour rail de avec bus données, compatible avec : AAG-Stucchi avec bus de données et Nordic / Global Track Pulse.

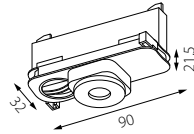

02 STUCCHI NON-DIM ADAPTER



424-9009-4-B

424-9009-4-W

Universal-Adapter für nicht dimmbare 3-Phasen Schiene.

Universal adapter for non-dimmable 3-phase rail.

Adaptateur universel pour rail triphasé non graduable.

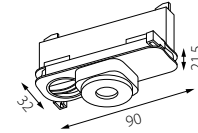

3 PHASE ADAPTER COMPATIBILITY

zenit M		meteor	
1	G	1	G
non-dim	Stucchi OneTrack	non-dim	Stucchi OneTrack
STUCCHI	STUCCHI	Powergear	STUCCHI

Einsetzbar in folgenden Schienen. Es handelt sich hier nur um eine Empfehlung, es wird weder von planlicht, noch vom Hersteller Garantie übernommen.
 Can be used on the following tracks. This is only for information, planlicht nor the manufacturer will warranty any claim when not used in an approved track.
 Compatibles avec les rails suivants. Les informations ci-après sont uniquement données à titre indicatif. planlicht et le fabricant déclinent toute garantie.

Ivela, Eutrac, Stucchi, Global, Unipro	Stucchi DALI, DALI Global Track Pulse Control, Unipro	Ivela, Eutrac, Stucchi, Global, Unipro	Stucchi DALI, DALI Global Track Pulse Control, Unipro
--	---	--	---

black
 white
 aluminium

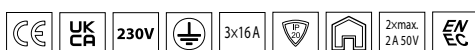

NOTLICHT & SENSOREN | EMERGENCY LIGHTING & SENSORS



PURE 3 / P.FORTY

direct	LO	HO	HCL
Length luminaire			
563 mm	-	-	-
633 mm	-	-	-
703 mm	-	-	-
773 mm	-	-	-
843 mm	-	-	-
913 mm	-	-	-
983 mm	-	-	-
1053 mm	●	●	-
1123 mm	●	●	●
1403 mm	●	●	●
1683 mm	●	●	●
2243 mm	●	●	●

PURE 3 / P.FORTY

direct / indirect	LO	HO	HCL
Length luminaire			
563 mm	-	-	-
633 mm	-	-	-
703 mm	-	-	-
773 mm	-	-	-
843 mm	-	-	-
913 mm	-	-	-
983 mm	-	-	-
1053 mm	-	●	-
1123 mm	●	●	●
1403 mm	●	●	●
1683 mm	●	●	●
2243 mm	●	●	●

P.FORTY

direct - asymmetric	LO	HO	HCL
Length luminaire			
563 mm	-	-	-
633 mm	-	-	-
703 mm	-	-	-
773 mm	-	-	-
843 mm	-	-	-
913 mm	-	-	-
983 mm	-	-	-
1053 mm	●	●	-
1123 mm	●	●	●
1403 mm	●	●	●
1683 mm	●	●	●
2243 mm	●	●	●

P.FORTY

direct / indirect - asymmetric	LO	HO	HCL
Length luminaire			
563 mm	-	-	-
633 mm	-	-	-
703 mm	-	-	-
773 mm	-	-	-
843 mm	-	-	-
913 mm	-	-	-
983 mm	-	-	-
1053 mm	-	●	-
1123 mm	●	●	●
1403 mm	●	●	●
1683 mm	●	●	●
2243 mm	●	●	●

QUADRO

surface - BAP

Length luminaire + 300 mm	LO	HO	HCL
1124 mm	●	●	●
1404 mm	●	●	●
1684 mm	●	●	●
2244 mm	●	●	●
2804 mm	●	●	●
3364 mm	●	●	●

QUADRO

surface - satined, micro

Length luminaire + 300 mm	LO	HO	HCL
1130 mm	●	●	●
1410 mm	●	●	●
1690 mm	●	●	●
2250 mm	●	●	●
2810 mm	●	●	●
3370 mm	●	●	●

QUADRO

pendant - direct - direct / indirect - satined, micro

Length luminaire + 300 mm	LO	HO	HCL
1130 mm	●	●	●
1410 mm	●	●	●
1690 mm	●	●	●
2250 mm	●	●	●
2810 mm	●	●	●
3370 mm	●	●	●

QUADRO

recessed frame - BAP - satiné - micro

Length luminaire	LO	HO	HCL
576 mm	●	●	-
1136 mm	●	●	-
1416 mm	●	●	-
1696 mm	●	●	-
2256 mm	●	●	-

QUADRO PENDANT

pendant - direct - direct / indirect - BAP

Length luminaire + 300 mm	LO	HO	HCL
1124 mm	●	●	●
1404 mm	●	●	●
1684 mm	●	●	●
2244 mm	●	●	●
2804 mm	●	●	●
3364 mm	●	●	●

TRIFLECT INSET PURE 3

direct - direct / indirect

Length luminaire	LO	HO
564 mm	-	-
1790 mm	●	●
2000 mm	●	●

SPOT 90 EZ

●

METEOR EB / FLIP - METIS M - TAURUS M - MIZAR M

LO	MO	HO	VHO
●	●	●	-

DIVA M

LO	HO
●	●

COSMO L - COSMO XL

LO	HO	VHO
●	●	-

METIS - TAURUS

LO	MO	HO
●	●	●

LILIBET

surface / pendant - direct - direct / indirect

	LO	HO / VHO	HCL
330 mm	●	●	●
420 mm	●	●	●
620 mm	●	●	●

ANTO+

frame / frameless

	LO	HO	HCL
2 spots	-	-	-
4 spots	●	●	-
6 spots	●	●	-
8 spots	●	●	-
12 spots	●	●	-
18 spots	-	-	-

SINUS RING

pendant / surface - direct

	LO	HO	HCL
1174 mm	●	●	●
1530 mm	●	●	●
2950 mm	●	●	●
5790 mm	●	●	●

SINUS RING FRAME

direct

	LO	HO	HCL
1190 mm	●	●	●
1546 mm	●	●	●
2966 mm	●	●	●
5806 mm	●	●	●

SINUS RING

pendant - direct / indirect

	LO	HO	HCL
1174 mm	●	●	●
1530 mm	●	●	-
2950 mm	●	●	-
5790 mm	●	●	●

SINUS SEGMENTS

direct

	LO	HO	HCL
552 / 45°	-	-	-
552 / 90°	-	-	-
730 / 45°	-	-	-
730 / 90°	●	●	-
1440 / 45°	●	●	●
1440 / 90°	●	●	●
2860 / 45°	●	●	●

SINUS SEGMENTS

direct/indirect	LO	HO	HCL
552/45°	-	-	-
552/90°	-	-	-
730/45°	-	-	-
730/90°	●	●	-
1440/45°	●	●	-
1440/90°	●	●	●
2860/45°	●	●	●

OPHELIA

surface/pendant/recessed - direct	LO	HO/VHO	HCL
330mm	●	●	●
420mm	●	●	●
620mm	●	●	●
920mm	●	●	●
1220mm	●	●	●

OPHELIA

surface/pendant - direct/indirect	LO	HO/VHO	HCL
330mm	●	●	●
420mm	●	●	●
620mm	●	○ (except VHO)	●
920mm	●	●	●
1220mm	●	●	●

OLMO

surface/pendant - direct	LO	HO	HCL
330x330mm	●	●	●
465x465mm	●	●	●
594x594mm	●	●	●
892x892mm	●	●	●
1166x1166mm	●	●	●

OLMO

surface/pendant - direct/indirect	LO	HO	HCL
330x330mm	●	●	●
465x465mm	●	●	●
594x594mm	○ (only surface)	○ (only surface)	○ (only surface)
892x892mm	●	●	●
1166x1166mm	●	●	●

ZENIT M

recessed	LO	MO	HO	VHO
-	-	●	●	●

LEDA/LEDA M

250mA	350mA	500mA	700mA
-	●	●	●

LIHA

recessed	LO	HO	HCL
330x330mm	●	●	●
470x470mm	●	●	●
620x620mm	●	●	●
910x910mm	●	●	●
1200x1200mm	●	●	●

ODELIA

surface/pendant - direct	LO	HO/VHO	HCL
330mm	●	●	●
420mm	●	●	●
620mm	●	●	●

ODELIA

surface/pendant - direct/indirect	LO	HO/VHO	HCL
330mm	●	●	●
420mm	●	●	●
620mm	●	○ (except VHO)	●

- Notlichttaugliche Variante erhältlich | *Emergency lighting available*
- Notlichttaugliche Variante teilweise erhältlich | *Emergency lighting partially available*
- Notlichttaugliche Variante nicht erhältlich | *Emergency lighting not available*

	Erstladung <i>Initial charging</i>	Schnellladung <i>Quick charging</i>	Erhaltungsladung <i>Trickle charging</i>
①	1,5W	1,5W	1,5W
②	1,0W	1,1W	0,7W
③	3,7W	4,1W	2,8W

SENSORS

Stand alone, ambient light & motion detection
BLINDADECKUNG | *BLANK COVER*



QUADRO HCL	P.THIRTY	P.FORTY HCL	PURE 3 HCL	HALO, SINUS, LILIBET HCL
	Length luminaire +190mm	Length luminaire +70mm	Length luminaire +50mm	only extern
Length luminaire +70mm				

INSTALLED IN LUMINAIRE

OPHELIA, ODELIA	OLMO	SKAI

WICHTIGE HINWEISE

Dieser Katalog richtet sich ausschliesslich an gewerbliche Kunden. Die in diesem Katalog angegebenen Werte sind Bemessungswerte und unterliegen produktionsbedingten Toleranzen*. Alle angeführten Angaben – insbesondere Grössen-, Material-, Farb- und technische Angaben – entsprechen dem Stand zum Zeitpunkt des Drucks und dienen ausschliesslich zur Information. Der Herausgeber haftet nicht für Satz- und Druckfehler sowie für Abweichungen der Produkte von Abbildungen und Angaben. PLANLICHT behält sich vor, jederzeit ohne Ankündigung Änderungen an Produkten vor zu nehmen. Es gelten die Allgemeinen Geschäftsbedingungen der planlicht GmbH & Co KG, die unter WWW.PLANLICHT.COM/AGB-LANDING/ eingesehen werden können.

Technische Kennzahlen, angeführte Werte und die Piktogrammleiste betreffen zumindest einen aber nicht zwingend alle Artikel der jeweiligen Leuchtenfamilie, exakte Angaben je Artikel finden Sie im Online-Katalog bzw. in PLANLICHT-Verkaufsbelegen und Datenblättern.

WEEE-Reg.-Nr. DE 54728470

* Leistung, Lichtstrom und Farbtemperatur unterliegen durch den Einsatz von elektronischen Bauteilen produktionsbedingten Toleranzen. Toleranzen Leistung und Lichtstrom: +/- 10%. Toleranz Farbtemperatur: +/- 150 K. Lichtstrom dynamisch weiss bei 2700 K.

IMPORTANT REMARKS

This catalogue is reserved for professionals only. The values published in this catalogue are rated values, which can slightly change for reasons related to the production process. The published data such as dimensions, materials, colours and technical data are valid at time of printing, and exclusively provided for informational purposes. The editor takes no responsibility for typographical and print errors, as well as for any differences in the products, pictures and data. PLANLICHT reserves the right to change the products at any time and without any notice. The Terms and Conditions of planlicht GmbH & Co KG (available on WWW.PLANLICHT.COM/AGB-LANDING/) shall apply.*

Key technical specifications, listed values as well as the pictogram bar relate to at least one but not necessarily all items of the respective luminaire family, exact details for each item can be found in the online web catalogue or in PLANLICHT sales documents and data sheets.

** The power output, luminous flux and colour temperature can be slightly different due to specific electronic components used in the manufacturing process. The power output and luminous flux can differ by +/- 10%. The colour temperature can differ by +/- 150K. Luminous flux dynamic white at 2700K.*

RELEVANTE INFORMATIONEN AUF EINEN BLICK

- Allgemeine Geschäfts- & Lieferbedingungen – Die Grundlage unserer Zusammenarbeit
- Garantie 66 – Das Qualitätsversprechen im Detail
- Technische Hinweise – Wichtige Informationen zur Planung
- Produktseiten – So lesen Sie unsere Übersichten
- Artikelnummer – Die Logik hinter dem Code
- Piktogramme – Die Symbole und ihre Bedeutung



RELEVANT INFORMATION AT A GLANCE

- *Terms & Conditions – The Basis of Our Cooperation*
- *Guarantee 66 – Our Commitment to Quality*
- *Technical Notes – Essential Guidance for Planning*
- *Product Pages – How to Read Our Overviews*
- *Article Number – The Logic Behind the Code*
- *Pictograms – The Meaning Behind the Symbols*

IMPRINT

Publisher: planlicht GmbH & Co. KG, Vomp
Creative Concept: Katrin Atzinger
Graphic Design: Beatrice Praxmarer, Christoph Höflinger
Print: Kraller Druck, Vahrn (BZ)
© 2026



6134 Vomp, Austria, Au 25
Tel. +43-5242-71608, Fax +43-5242-71283
info@planlicht.com
WWW.PLANLICHT.COM



FEATURES & ZUBEHÖR

FEATURES & ADDITIONAL EQUIPMENT