

AKUSTIK

ACOUSTIC

 planlicht

AKUSTIK |
ACOUSTICS

DIE QUIET-PRODUKTLINIE VON PLANLICHT: EIN HIGHLIGHT FÜR AUGEN & OHREN

THE QUIET PRODUCT-LINE: STRIKING DESIGN & IMMERSIVE SOUND



AKUSTIK UND LICHT IN PERFEKTER HARMONIE DIE INTEGRATION VON AKUSTIK IN DIE BELEUCHTUNG

Bei PLANLICHT steht zwar Licht im Fokus, allerdings ist uns auch die ganzheitliche Gestaltung von Raumqualität wichtig. Mit der quiet-Produktlinie wird die Beleuchtung durch innovative Akustiktechnologie ergänzt, die die Raumakustik positiv beeinflusst. So entstehen nicht nur perfekt ausgeleuchtete, sondern auch akustisch optimierte Umgebungen. Neben exklusiven architektonischen Lichtlösungen bietet PLANLICHT Akustikleuchten und -paneele, die mit hochwertigen Naturmaterialien wie Heu und Schafwolle ausgestattet sind. Diese phonoabsorbierenden Materialien filtern störende Geräusche, reduzieren die Nachhallzeit und schaffen so eine ruhige Atmosphäre - selbst in Räumen mit hohem Geräuschpegel. Aktuell umfasst die quiet-Serie vier Leuchten: die Profileuchten p.forty, quadro und pure 3 sowie die Ringleuchte sinus. Diese multifunktionalen Leuchten bieten nicht nur außergewöhnliche Lichttechnik, sondern auch akustische Eigenschaften, die Räume in eine harmonische audiovisuelle Umgebung verwandeln.

ACOUSTIC AND LIGHT IN PERFECT HARMONY THE INTEGRATION OF ACOUSTICS INTO LIGHTING

At PLANLICHT, while our primary focus is on lighting, we also place great importance on the overall quality of the space. With the quiet product line, lighting is enhanced by innovative acoustic technology that positively impacts the room's acoustics. This results in environments that are not only perfectly lit but also acoustically optimised. In addition to exclusive architectural lighting solutions, PLANLICHT offers acoustic luminaires and panels made from high-quality natural materials such as hay and sheep wool. These sound-absorbing materials filter out disruptive noises, reduce reverberation time, and create a calm atmosphere - even in spaces with high noise levels. Currently, the quiet series includes four luminaires: the profile lights p.forty, quadro, and pure 3, as well as the circular luminaire sinus. These multifunctional luminaires combine exceptional lighting technology with acoustic features, transforming spaces into harmonious audiovisual environments.

GUT ZU WISSEN: AKUSTIK IM RAUM

GOOD TO KNOW: ACOUSTIC INFLUENCES IN ROOMS

WIE VERSCHIEDENE FAKTOREN DIE RAUMAKUSTIK BEEINFLUSSEN

Die Akustik eines Raumes wird von zahlreichen Faktoren beeinflusst:

DECKE: Da die Decke häufig die größte freie Fläche im Raum darstellt, kann eine akustisch optimierte Decke oder eine Akustikleuchte die Geräuschkulisse erheblich verbessern.

WÄNDE: Wände reflektieren den Schall und können dadurch die Schallwellen verstärken. Schallabsorbierende Wandelemente wie Bilder oder Absorberplatten reduzieren diese Reflektionen.

BODEN: Teppiche absorbieren Trittschall und verringern die Schallreflexionen. Harte Böden wie Parkett hingegen verstärken die Schallreflexion.

MÖBEL: Möbel ohne akustische Optimierung tragen zur Schallreflexion bei, während speziell angepasste Möbelloberflächen die Akustik im Raum positiv beeinflussen.

FENSTER: Fensterflächen reflektieren Schall, wodurch der Lärmpegel steigen kann. Schallabsorbierende Lamellen oder Vorhänge können diesen Effekt abschwächen.

MENSCHEN: Der menschliche Körper fungiert als natürlicher Schallabsorber und ersetzt bis zu 0,5 m² hochabsorbierendes Material.

PFLANZEN: Pflanzen können zwar das Raumklima verbessern, allerdings haben sie keinen nennenswerten Einfluss auf die Raumakustik oder die Schallabsorption.

HOW DIFFERENT FACTORS AFFECT ROOM ACOUSTICS

The acoustics of a room are influenced by various factors:

CEILING: *As the largest free surface in a room, the ceiling can have a significant impact on sound. An acoustically optimised ceiling or acoustic luminaire can drastically improve the sound environment.*

WALLS: *Walls reflect sound, which can amplify sound waves depending on the room's geometry. Acoustic wall elements such as images or absorber panels help to reduce these reflections.*

FLOOR: *Carpets absorb footstep noise and reduce sound reflections, whereas hard floors such as parquet amplify sound reflections.*

FURNITURE: *Furniture without acoustic optimisation reflects sound, while acoustically optimised furniture surfaces positively influence room acoustics.*

WINDOWS: *Window areas reflect sound, which can increase noise levels. Sound-absorbing blinds or curtains can help mitigate this effect.*

PEOPLE: *The human body acts as a natural sound absorber, replacing up to 0.5 m² of highly absorbent material.*

PLANTS: *While plants can improve the room's climate, they have no significant impact on acoustics or sound absorption.*

For further details on acoustics, visit the PLANLICHT website



Vertiefende Informationen rund um das Thema Akustik: PLANLICHT-Website

For further details on acoustics, visit the PLANLICHT website

AKUSTIK-ABSORBER ACOUSTIC ABSORBERS

Das Akustikelement gibt es wahlweise als porösen Absorber aus Filz in den Farben anthracite melange, pebble, blueberry, rust, lime und olive green.

Darüber hinaus kann aus den natürlichen ORGANOID® Oberflächen Wildspitze, Mous und Wollä gewählt werden. Organoid Technologies aus dem Tiroler Oberland beschichtet die Akustik Paneele mit handverlesenen Materialien. Neben den Klassikern gibt es die quiet-Serie auf Anfrage auch in vielen anderen außergewöhnlichen Oberflächen.

The acoustic element is available as a porous absorber made of felt in the colours anthracite melange, pebble, blueberry, rust, lime and olive green.

In addition, you can choose from the natural ORGANOID® surfaces Wildspitze, Mous and Wollä. Organoid Technologies from the Tyrolean Oberland coats the acoustic panels with hand-picked materials. In addition to the classics, the quiet series is also available in many other outstanding surfaces on request.

ORGANOID®



WILDSPITZE

WOLLÄ

MOUS

FELT.QUIET



ANTHRACITE MELANGE

PEBBLE

BLUEBERRY

RUST

LIME

OLIVE GREEN



BILDUNGSEINRICHTUNG DES BUNDES | LEIPZIG, DEUTSCHLAND

BILDUNGSEINRICHTUNG DES BUNDES | LEIPZIG, GERMANY

Foto: © pkfotografie

Photo: © pkfotografie



INSPIRATION

Produkt: sinus.quiet

INSPIRATION

Product: sinus.quiet

AKUSTIKPLANUNG MIT PLANLICHT

ACOUSTIC PLANNING WITH PLANLICHT

MASSGESCHNEIDERTE LÖSUNGEN FÜR OPTIMALE RAUMAKUSTIK

Eine fundierte Akustikplanung berücksichtigt die spezifischen Voraussetzungen jedes Raumes, um durch gezielte Maßnahmen die Nachhallzeit und den Schallpegel zu optimieren. Hierbei spielen folgende Parameter eine Rolle:

RAUMGEOMETRIE/RAUMVOLUMEN: Die Länge, Breite und Höhe des Raumes beeinflussen maßgeblich die Nachhallzeit.

MATERIALIEN: Die Reflexionswerte unterschiedlicher Materialien – von Wänden über Decken bis hin zu Böden und Fenstern – haben einen wesentlichen Einfluss auf die Raumakustik.

RAUMNUTZUNG: Je nach Nutzung des Raumes (z. B. Büro, Besprechungsraum, Restaurant) gelten unterschiedliche akustische Anforderungen.

BELEGUNG: Die Anzahl der Personen im Raum beeinflusst die Akustik, da jeder Mensch eine Fläche von 0,5 m² hoch absorbierendem Material entspricht.

Unsere Experten stehen Ihnen jederzeit zur Verfügung, um Sie in allen Fragen der Licht- und Akustikplanung zu beraten und Ihre Projekte mit maßgeschneiderten Lösungen zu unterstützen.

TAILORED SOLUTIONS FOR OPTIMAL ROOM ACOUSTIC

A thorough acoustic plan takes into account the specific characteristics of each room to optimise reverberation time and sound levels through targeted measures. The following factors are crucial:

ROOM GEOMETRY/VOLUME: *The length, width, and height of a room significantly affect the reverberation time.*

MATERIALS: *The reflection values of different materials - ranging from walls to ceilings, floors, and windows - have a substantial impact on room acoustics.*

ROOM USAGE: *Different uses for the room (e.g., office, meeting room, restaurant) require varying acoustic treatments.*

OCCUPANCY: *The number of people in a room affects the acoustics, as each person accounts for 0.5 m² of highly absorbent material.*

Our experts are always available to provide advice on both lighting and acoustic planning, offering bespoke solutions to support your projects.



Vertiefende Informationen rund um das Thema Akustik: PLANLICHT-Website

For further details on acoustics, visit the PLANLICHT website

AKUSTIK-PROJEKTE ACOUSTIC PROJECTS



INSPIRATION

Produkt: quadro.quiet

INSPIRATION

Product: quadro.quiet





INSPIRATION

Produkt: sinus.quiet

INSPIRATION

Product: sinus.quiet



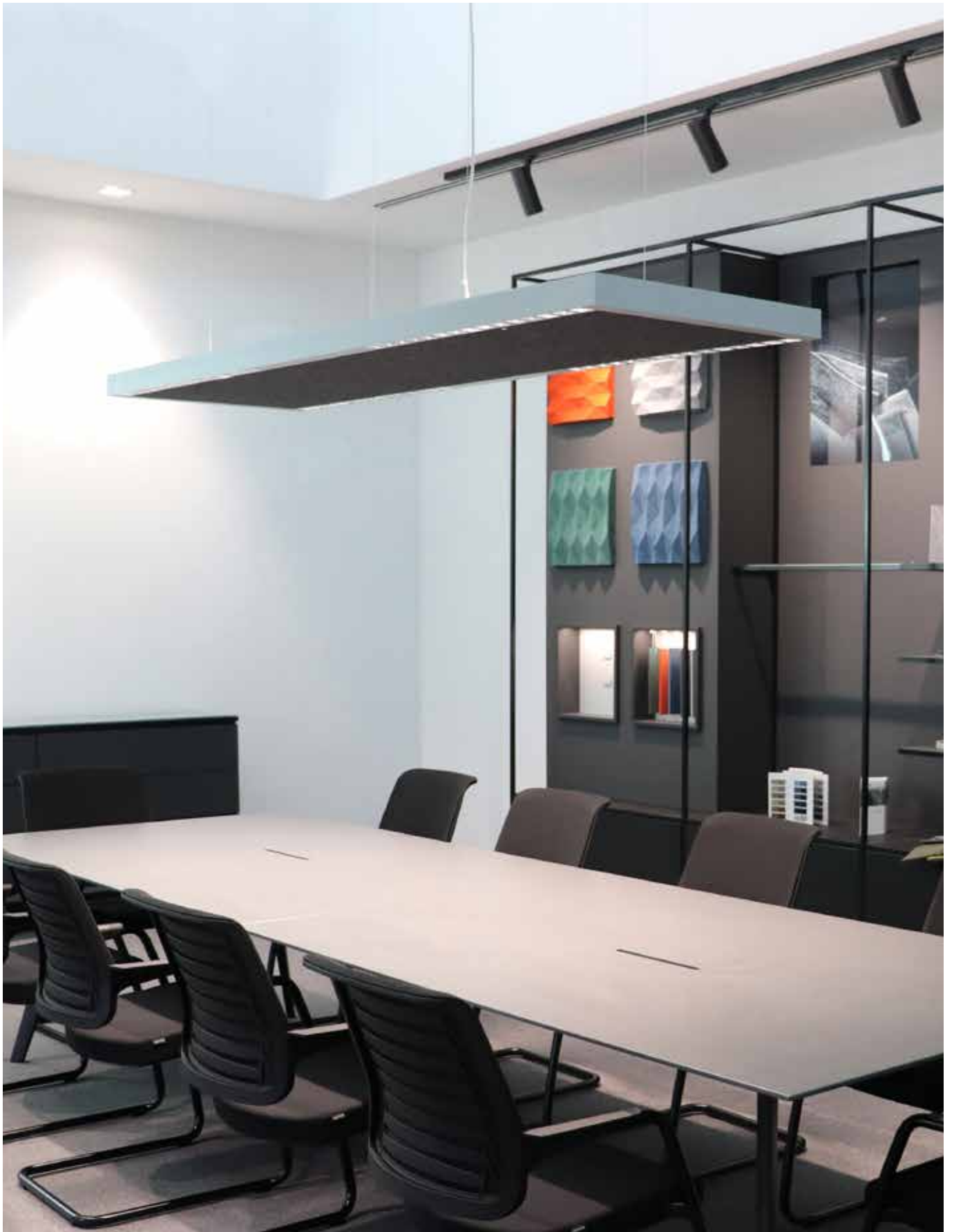

BWF GROUP SHOWROOM | DEUTSCHLAND

Produkt: quadro.quiet

BWF GROUP SHOWROOM | GERMANY

Product: quadro.quiet



RAMBOLL HEADQUARTERS LEPPAEVAAR | FINNLAND

Produkt: sinus.quiet

RAMBOLL HEADQUARTERS LEPPAEVAAR | FINNLAND

Product: sinus.quiet





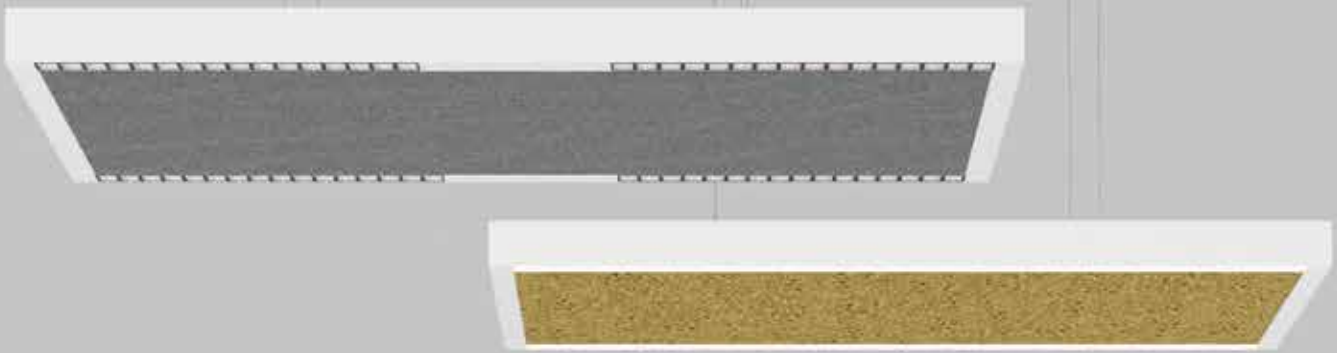

1 SIZE

1485 × 657 mm	14R
1765 × 657 mm	17R
3445 × 657 mm	34R

2 ACOUSTIC MODULE

	QUIET.FELT anthracite melange	QA
	QUIET.FELT pebble	QP
	QUIET.FELT lime	QL
	QUIET.FELT olive green	QO
	QUIET.FELT rust	QR
	QUIET.FELT blueberry	QU
	Organoid* Mous	QM
	Organoid* Wollä	QW
	Organoid* Wildspitze	QH

3 HOUSING COLOUR

	silver	SI
	white	WS
	black	SW
	RAL of your choice	

4 DIRECT / INDIRECT

	direct (DI)	1
	direct/indirect (DI/ID)	2

5 LED

	3000K, CRI > 80 (not BAP)	830
	4000K, CRI > 80 (not BAP)	840
	3000K, CRI > 90	930
	4000K, CRI > 90	940
	2700 - 6500K dynamic white, CRI > 90	HCL

6 OUTPUT / CONTROL

	low output non-dim	L1
	low output DALI	L3
	high output DALI	H3
	dynamic white	X3

7 OPTIC

	BAP	
	S silver matte*	P
	M silver semi-matte*	3
	gold semi-matte*	2
	copper semi-matte*	4
	black chrome semi-matte*	1

* UGR-optimised, configure online

P40H1-2C34567

P40H14R-QAWSC1840H3S 1485 × 657 mm, acoustic module anthracite melange, housing white, 4000K, CRI > 80, high output DALI, satiné (order sample)

► Configure online on KATALOG.PLANLICHT.COM

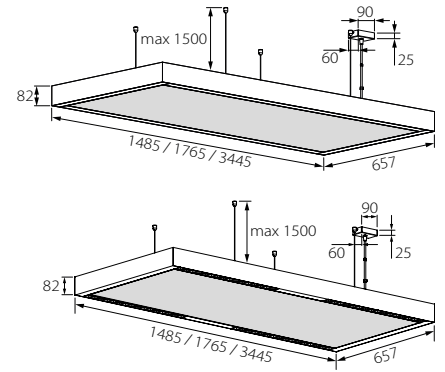
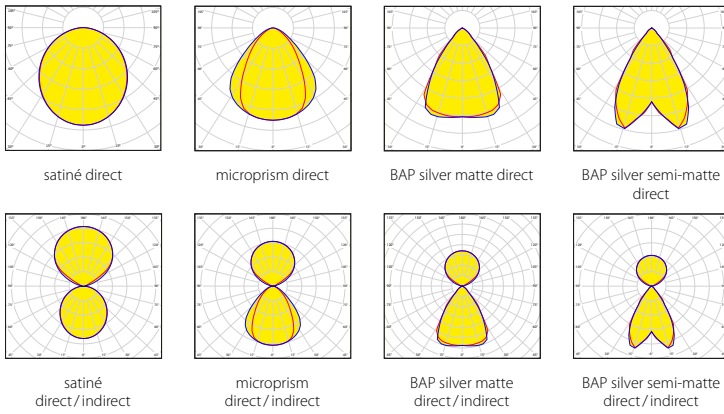

LUMINOUS FLUX (LM) / SYSTEM POWER (W), CRI > 90

4000K satiné	low output		high output		dynamic white		kg
	DI	DI/ID	DI	DI/ID	DI	DI/ID	
1458 x 657 mm	4652 lm / 34,5W	9971 lm / 64,3W	7577 lm / 56,8W	16183 lm / 108,3W	6702 lm / 57,1W	14314 lm / 108,9W	14,3 kg
1765 x 657 mm	5584 lm / 40,4W	11966 lm / 76,3W	9081 lm / 66,6W	19408 lm / 127,1W	8032 lm / 67,7W	17166 lm / 129,2W	17,4 kg
3445 x 657 mm	11080 lm / 80,9W	23845 lm / 152,6W	17812 lm / 133,2W	38465 lm / 254,2W	15754 lm / 135,3W	34021 lm / 258,3W	31,3 kg

(based on optic S, DALI)

COMPARE COVER, CRI > 90

4000K 1485 x 657 mm	low output		high output		dynamic white	
	DI	DI/ID	DI	DI/ID	DI	DI/ID
satiné	4652 lm	9971 lm	7577 lm	16183 lm	6702 lm	14314 lm
microprism*	4676 lm	9995 lm	7615 lm	16221 lm	6736 lm	14348 lm

COMPARE LIGHT COLOUR 1485 x 657 MM, SATINÉ, CRI > 90

4000 K	4652 lm	-0,8%
3000 K	4409 lm	-3,3%

LUMINOUS FLUX (LM) / SYSTEM POWER (W), CRI > 90

4000K BAP silver matte	low output		high output		dynamic white		kg
	DI	DI/ID	DI	DI/ID	DI	DI/ID	
1458 x 657 mm	3765 lm / 31W	8833 lm / 61W	7188 lm / 55W	16509 lm / 114W	6369 lm / 64W	14613 lm / 120W	15,1 kg
1765 x 657 mm	3765 lm / 31W	9900 lm / 67W	7188 lm / 55W	18471 lm / 127W	6369 lm / 64W	16349 lm / 132W	17,2 kg
3445 x 657 mm	7529 lm / 61W	19802 lm / 131W	14375 lm / 108W	36941 lm / 251W	12739 lm / 120W	32698 lm / 258W	30,4 kg

(based on DALI)

COMPARE COVER BAP, CRI > 90

4000K 1485 x 657 mm	low output		high output		dynamic white	
	DI	DI/ID	DI	DI/ID	DI	DI/ID
black chrome semi-matte	3050 lm	8118 lm	5823 lm	15144 lm	5160 lm	13404 lm
gold semi-matte	3798 lm	8866 lm	7252 lm	16573 lm	6427 lm	14671 lm
silver semi-matte	3980 lm	9048 lm	7599 lm	16920 lm	6734 lm	14978 lm
copper semi-matte	3783 lm	8851 lm	7224 lm	16545 lm	6401 lm	14645 lm
silver matte	3765 lm	8833 lm	7188 lm	16509 lm	6369 lm	14613 lm

*Der angegebene Lichtstrom bezieht sich auf die Leuchte mit klarer mikroprismatischer Abdeckung. Die Leuchte wird mit satiniertes Folie zur Erhöhung der Homogenität geliefert (direkt strahlend: -22,8%, direkt/indirekt strahlend: -9,8% Lichtstrom).

The indicated luminous flux corresponds to the luminaire with a clear microprismatic diffuser. The luminaire is delivered with a satined-foil for increased homogeneity (direct: -22,8%, direct-indirect: -9,8% luminous flux).

ACOUSTIC ABSORBERS



WILDSPITZE

WOLLÄ

MOOS



ANTHRACITE MELANGE

PEBBLE

BLUEBERRY

RUST

LIME

OLIVE GREEN

P.FORTY BAP LOUVRE

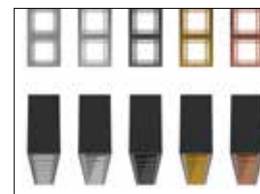

Down to UGR ≤ 16 | up to 157 lm/W | IEC 62471: Blue light hazard: RG 0 | DALI switchDIM

pure 3.quiet

Hängeleuchte
Pendant luminaire

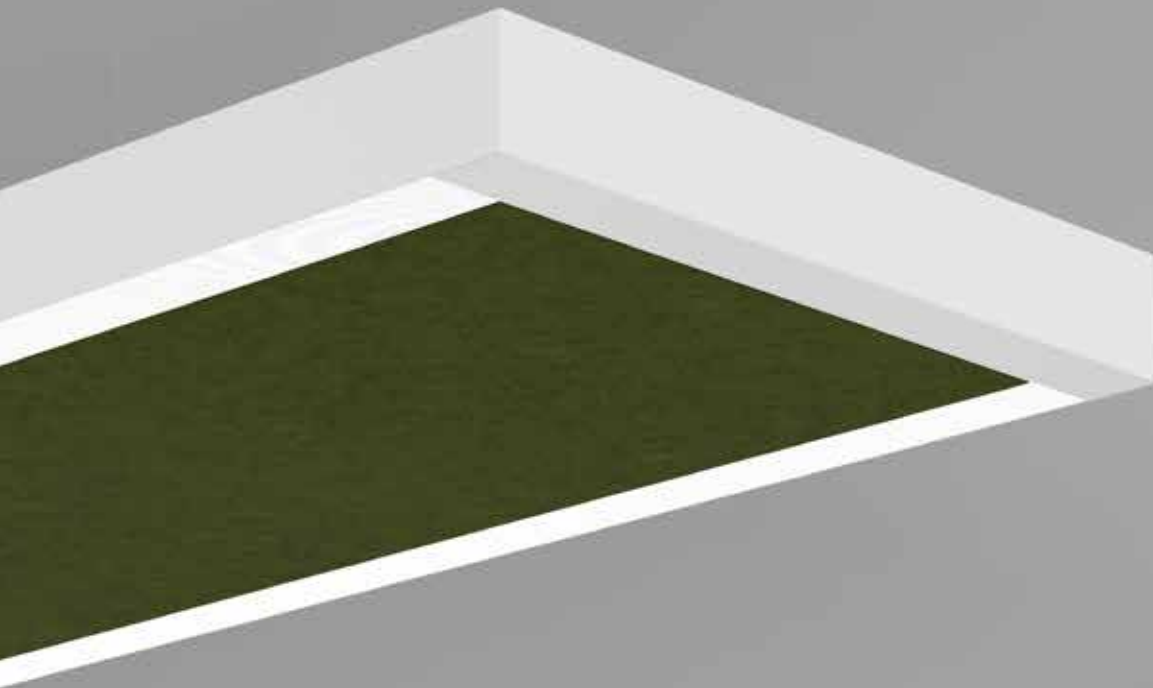

1 SIZE

1538 x 710 mm	15R
1818 x 710 mm	18R
3498 x 710 mm	34R

2 ACOUSTIC MODULE

	QUIET.FELT anthracite melange	QA
	QUIET.FELT pebble	QP
	QUIET.FELT lime	QL
	QUIET.FELT olive green	QO
	QUIET.FELT rust	QR
	QUIET.FELT blueberry	QU
	Organoid* Mous	QM
	Organoid* Wollä	QW
	Organoid* Wildspitze	QH

3 HOUSING COLOUR

	silver	SI
	white	WS
	black	SW
	RAL of your choice	

4 DIRECT / INDIRECT

	direct (DI)	1
	direct/indirect (DI/ID)	2

5 LED

	3000K, CRI > 80	830
	4000K, CRI > 80	840
	3000K, CRI > 90	930
	4000K, CRI > 90	940
	2700 - 6500K dynamic white, CRI > 90	HCL

6 OUTPUT / CONTROL

	low output non-dim	L1
	low output DALI	L3
	high output DALI	H3
	dynamic white	X3

7 OPTIC

	HE** PMMA satiné	O
	HE** PMMA structured microprism*	T
	satiné	S
	microprism*	M

* UGR-optimised, configure online |
** High efficiency

P33H1-2-3-4-5-6-7

P33H18R - QPSWC1840H3S 1818 x 710 mm, acoustic module pebble, housing black, IP20, direct, 4000K, CRI > 80, high output DALI, satiné (order sample)

► Configure online on KATALOG.PLANLICHT.COM

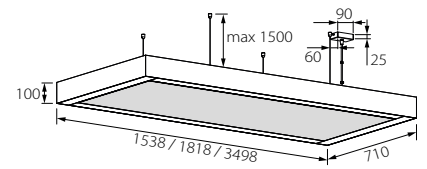
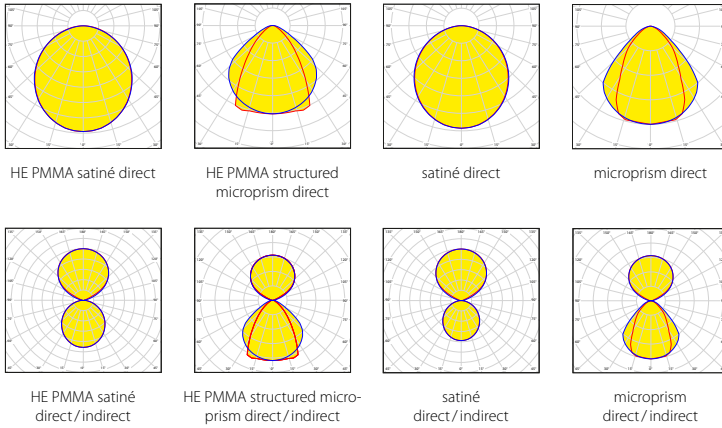

LUMINOUS FLUX (LM) / SYSTEM POWER (W), CRI > 90

4000K HE PMMA satiné	low output		high output		dynamic white		kg
	DI	DI/ID	DI	DI/ID	DI	DI/ID	
1538 x 710 mm	4845 lm / 34,5W	10164 lm / 64,3W	7976 lm / 56,8W	16582 lm / 108,3W	7054 lm / 57,1W	14666 lm / 108,9W	19,0 kg
1818 x 710 mm	5786 lm / 40,4W	12168 lm / 76,3W	9524 lm / 66,6W	19851 lm / 127,1W	8423 lm / 67,7W	17557 lm / 129,2W	22,7 kg
3498 x 710 mm	11133 lm / 80,9W	23898 lm / 152,6W	18322 lm / 133,2W	38975 lm / 254,2W	16206 lm / 135,3W	34473 lm / 258,3W	40,1 kg

(based on optic S, DALI)

*Der angegebene Lichtstrom bezieht sich auf die Leuchte mit klarer mikroprismatischer Abdeckung. Die Leuchte wird mit satinierter Folie zur Erhöhung der Homogenität geliefert (direkt strahlend: -26,1%, direkt/indirekt strahlend: -12,5% Lichtstrom).

**Der angegebene Lichtstrom bezieht sich auf die Leuchte mit klarer mikroprismatischer Abdeckung. Die Leuchte wird mit satinierter Folie zur Erhöhung der Homogenität geliefert (direkt strahlend: -15,2%, direkt/indirekt strahlend: -7,8% Lichtstrom).

COMPARE COVER, CRI > 90

4000 K 1538 x 710 mm	low output		high output		dynamic white	
	DI	DI/ID	DI	DI/ID	DI	DI/ID
satiné	4083 lm	9402 lm	6721 lm	15327 lm	5945 lm	13557 lm
microprism*	4489 lm	9808 lm	7389 lm	15995 lm	6536 lm	14148 lm
HE PMMA satiné	4845 lm	10164 lm	7976 lm	16582 lm	7054 lm	14666 lm
HE PMMA structured microprism**	5123 lm	10442 lm	8433 lm	17039 lm	7459 lm	15071 lm

COMPARE LIGHT COLOUR 1538 X 710 MM, HE PMMA SATINÉ, LOW OUTPUT, CRI > 90

4000 K	4845 lm
3000 K	4592 lm

ACOUSTIC ABSORBERS



WILDSPITZE

WOLLÄ

MOUS



ANTHRACITE MELANGE

PEBBLE

BLUEBERRY

RUST

LIME

OLIVE GREEN

PURE 3 PROFILE SYSTEM



Down to UGR ≤ 16 | up to 164 lm/W | IEC 62471: Blue light hazard: RG 0 | DALI switchDIM

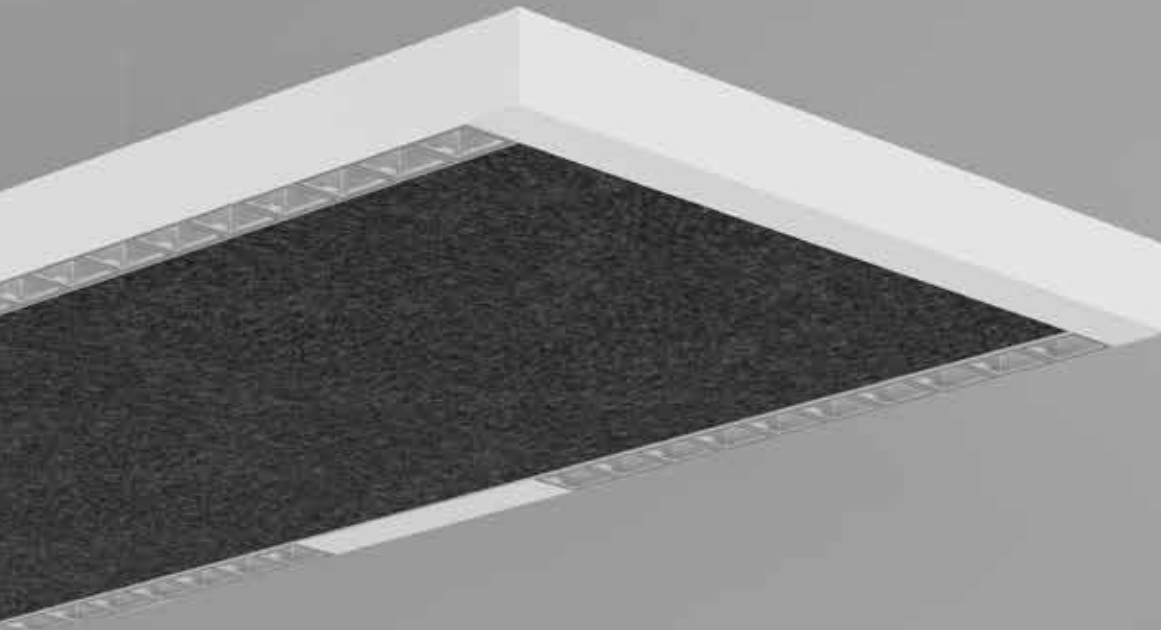

1 VERSION

quadro	5
quadro.green	G

2 SIZE

1498 mm	15X
1778 mm	17X
3458 mm	34X

3 ACOUSTIC MODULE

	QUIET.FELT anthracite melange	QA
	QUIET.FELT pebble	QP
	QUIET.FELT lime	QL
	QUIET.FELT olive green	QO
	QUIET.FELT rust	QR
	QUIET.FELT blueberry	QU
	Organoid® Mous	QM
	Organoid® Wollä	QW
	Organoid® Wildspitze	QH

4 HOUSING COLOUR

	silver	SI
	white	WS
	black	SW
	RAL of your choice	

5 LED

	3000 K, CRI > 80	830
	4000 K, CRI > 80	840
	3000 K, CRI > 90	930
	4000 K, CRI > 90	940
	2700-6500 K, dynamic white, CRI > 90	HCL

6 OUTPUT / CONTROL

	non Sensor	Sensor
	low output non-dim	L1 -
	low output DALI	L3 L7
	high output DALI	H3 H7
	dynamic white	X3 X7*

* on request

7 BAP LOUVRE COLOURS

BAP high-gloss silver*	B	BAP glaring gold*	D
BAP silver matte*	P	BAP capital copper*	R
BAP high-gloss gold*	G	BAP gunnery grey*	Y
BAP high-gloss copper*	K	BAP high gloss black chrome*	Z
BAP white (RAL 9016, low output) *	W	PLF Parabolic Louvre Flat silver semi-matte*	F
BAP black (RAL 9005)*	N		

* UGR-optimised, configure online

T6 1 H 2 - 3 4 C 2 5 6 7

T65H17X-QLSWC2840H3Y pendant, 1778 mm, lime acoustic module, housing black, IP20, direct & indirect, 4000K, CRI > 80, high output DALI, BAP gunnery grey (order sample) [► Configure online on KATALOG.PLANLICHT.COM](https://www.planlicht.com)

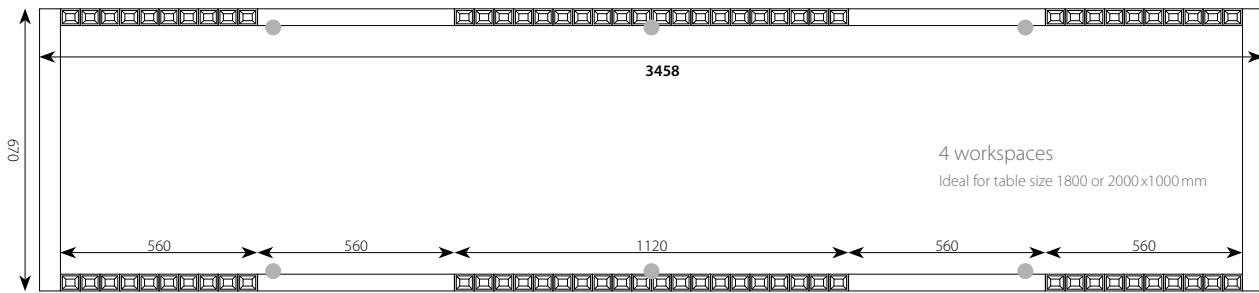
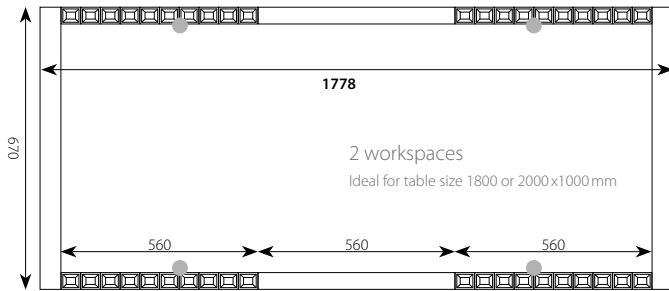
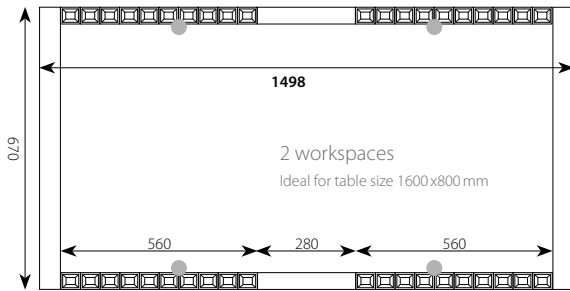
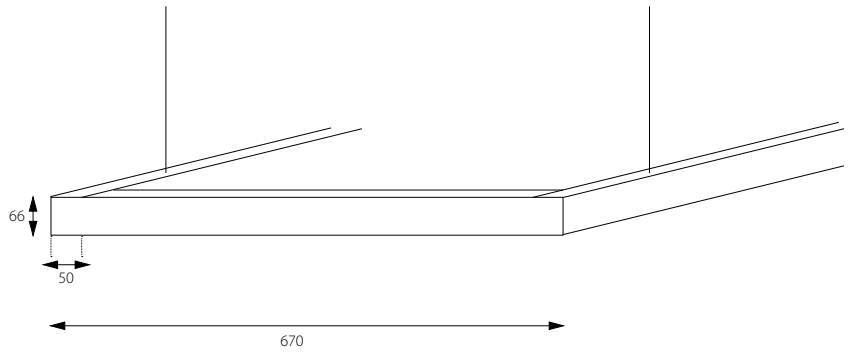
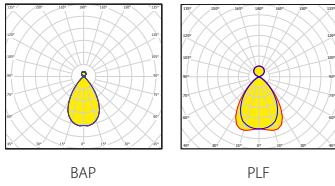

LUMINOUS FLUX (LM) / SYSTEM POWER (W)

4000K BAP silver matte	low output CRI > 80	high output CRI > 80	dynamic white CRI > 90	
1498x670mm	5584lm / 46W	10948lm / 94W	8686lm / 96W	16 kg
1778x670mm	5869lm / 47W	11512lm / 98W	9133lm / 99W	17 kg
3458x670mm	11167lm / 91W	21893lm / 188W	17368lm / 192W	31 kg

COMPARE BAP LOUVRES 1498 x 670 MM



	low output CRI > 80	high output CRI > 80	dynamic white CRI > 90
B	6228lm	12205lm	9684lm
P	5584lm	10948lm	8686lm
G	5816lm	11402lm	9046lm
K	5789lm	11349lm	9004lm
W	4247lm	-	-
N	3812lm	7488lm	5940lm
D	4219lm	8282lm	6570lm
R	3963lm	7783lm	6174lm
Y	4247lm	8337lm	6614lm
Z	5037lm	9879lm	7837lm
F	7313lm	11325lm	8985lm



Down to UGR ≤ 16 | up to 145 lm/W | IEC 62471: Blue light hazard: RG 0 | DALI switchDIM



1 SUSPENSION STYLE

	Rope vertical	H
	Rope centrally merging	Z





2 SIZE

ø 1174 mm	117
ø 1530 mm	153



3 ACOUSTIC MODULE

	QUIET.FELT anthracite melange	QA
	QUIET.FELT pebble	QP
	QUIET.FELT lime	QL
	QUIET.FELT olive green	QO
	QUIET.FELT rust	QR
	QUIET.FELT blueberry	QU
	Organoid® Mous	QM
	Organoid® Wollä	QW
	Organoid® Wildspitze	QH





4 HOUSING COLOUR

	silver	SI
	white	WS
	black	SW
	RAL of your choice	





5 DIRECT / INDIRECT

	direct	1
	direct/indirect	2



6 LED

	3000 K, CRI > 80	830
	4000 K, CRI > 80	840
	3000 K, CRI > 90	930
	4000 K, CRI > 90	940
	2700 - 6500 K dynamic white, CRI > 90	HCL

7 OUTPUT / CONTROL

	low output non-dim	L1
	low output DALI	L3
	high output DALI	H3
	dynamic white	X3

8 OPTIC

	satiné	S
	microprism*	M

* UGR-optimised, configure online

R33 **1 2 3 4 E 5 6 7 8**

R33Z117-QPWE1840H3S pendant, rope centrally merging, ø 1174 mm, acoustic module pebble, housing white, IP40, direct, 4000 K, CRI > 80, high output DALI, satiné (order sample)

► Configure online on KATALOG.PLANLICHT.COM

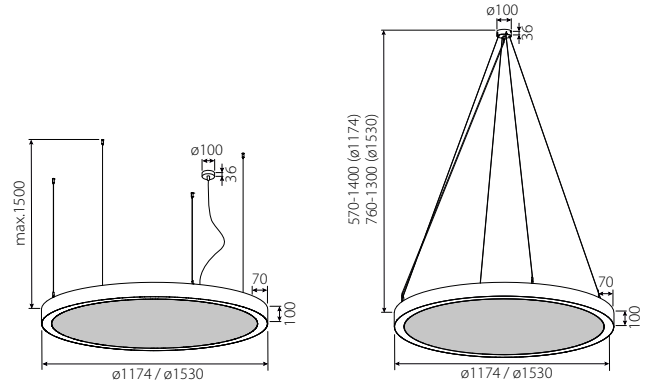
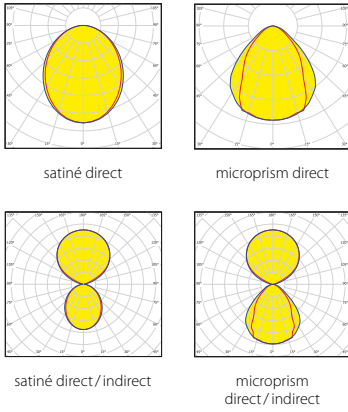

LUMINOUS FLUX (LM) / SYSTEM POWER (W), CRI > 90

4000K satiné	direct			direct/indirect			KG
	low output	high output	dynamic white	low output	high output	dynamic white	
ø 1174 mm	4836 lm / 42,8W	8645 lm / 79,8W	7687 lm / 82,9W	9897 lm / 85,6W	17692 lm / 159,5W	15732 lm / 165,8W	20,4 kg
ø 1530 mm	6448 lm / 56,8W	11527 lm / 105,2W	10250 lm / 109,3W	13196 lm / 113,5W	23589 lm / 210,5W	20976 lm / 218,6W	31,7 kg

(based on optic S, DALI)

COMPARE COVER Ø 1530 MM, 4000K, CRI > 90

	direct			direct/indirect		
	low output	high output	dynamic white	low output	high output	dynamic white
satiné	6448 lm	11527 lm	10250 lm	6448 lm	11527 lm	10250 lm
microprism*	6938 lm	12401 lm	11028 lm	6938 lm	12401 lm	11028 lm

COMPARE LIGHT COLOUR Ø 1530 MM, SATINÉ, LOW OUTPUT, CRI > 90

4000 K	6448 lm	-1,2%
3000 K	6162 lm	-3,1%

Der angegebene Lichtstrom bezieht sich auf die Leuchte mit klarer mikroprismatischer Abdeckung. Die Leuchte wird mit satinierter Folie zur Erhöhung der Homogenität geliefert (Direkt strahlend: -26,2% , direkt/indirekt strahlend: -1,3% Lichtstrom).

The indicated luminous flux corresponds to the luminaire with a clear microprismatic diffuser. The luminaire is delivered with a satined-foil for increased homogeneity (direct: -26,2% , direct-indirect: -13,3% luminous flux).

ACOUSTIC ABSORBERS



WILDSPITZE

WOLLÄ

MOUS



ANTHRACITE MELANGE

PEBBLE

BLUEBERRY

RUST

LIME

OLIVE GREEN



Down to UGR ≤ 16 | up to 122 lm/W | IEC 62471: Blue light hazard: RG 0 | DALI switchDIM



1 SIZE

ø 1190 mm

119

ø 1546 mm

154

2 ACOUSTIC MODULE

	QUIET.FELT anthracite melange	QA
	QUIET.FELT pebble	QP
	QUIET.FELT lime	QL
	QUIET.FELT olive green	QO
	QUIET.FELT rust	QR
	QUIET.FELT blueberry	QU
	Organoid® Mous	QM
	Organoid® Wollä	QW
	Organoid® Wildspitze	QH

3 COLOUR

	silver	SI
	white	WS
	black	SW
	RAL of your choice	

4 LED

	3000 K, CRI > 80	830
	4000 K, CRI > 80	840
	3000 K, CRI > 90	930
	4000 K, CRI > 90	940
	2700 - 6500 K dynamic white, CRI > 90	HCL

5 OUTPUT/CONTROL

	low output non-dim	L1
	low output DALI	L3
	high output DALI	H3
	dynamic white	X3

6 OPTIC

	satiné	S
	microprism*	M

* UGR-optimised, configure online

R33E1-23E1456

R33E119-QPWSE1840H3S frame, ø 1190 mm, acoustic module, pebble, housing white, 4000 K, CRI > 80, high output DALI, satiné (order sample)

► Configure online on KATALOG.PLANLICHT.COM

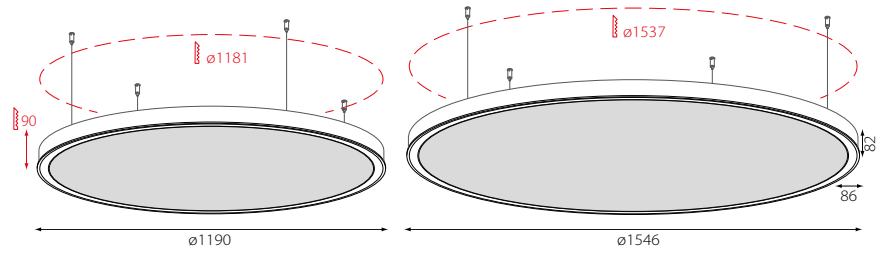
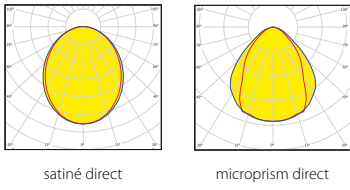

LUMINOUS FLUX (LM)/SYSTEM POWER (W), CRI > 90

4000K satiné	low output	high output	dynamic white	
ø 1190 mm	4836 lm / 42,8W	8645 lm / 79,8W	7687 lm / 82,9W	20,4 kg
ø 1546 mm	6448 lm / 56,8W	11527 lm / 105,2W	10250 lm / 109,3W	31,7 kg

COMPARE COVER Ø 1546 MM, 4000K, CRI > 90

	low output	high output	dynamic white
satiné	6448 lm	11527 lm	10250 lm
microprism*	6938 lm	12401 lm	11028 lm

COMPARE LIGHT COLOUR Ø 1546 MM, SATINÉ, CRI > 90

4000 K, CRI > 90	6448 lm	-1,2%
3000 K, CRI > 90	6162 lm	-3,1%

CUT OUT

SIZE	ø DIAMETER	↑ DEPTH
ø 1190 mm	ø 1181 mm	90 mm
ø 1546 mm	ø 1537 mm	90 mm

*Der angegebene Lichtstrom bezieht sich auf die Leuchte mit klarer mikroprismatischer Abdeckung. Die Leuchte wird mit satiniertes Folie zur Erhöhung der Homogenität geliefert (-28,2% Lichtstrom).
The indicated luminous flux corresponds to the luminaire with a clear microprismatic diffuser. The luminaire is delivered with a satined-foil for increased homogeneity (-28,2% luminous flux).

ACOUSTIC ABSORBERS



WILDSPITZE

WOLLÄ

MOUS



ANTHRACITE MELANGE

PEBBLE

BLUEBERRY

RUST

LIME

OLIVE GREEN



Down to UGR ≤ 19 | up to 122 lm/W | IEC 62471: Blue light hazard: RG 0 | DALI switchDIM

felt

Akustikpaneel
Acoustic panel



suspended round

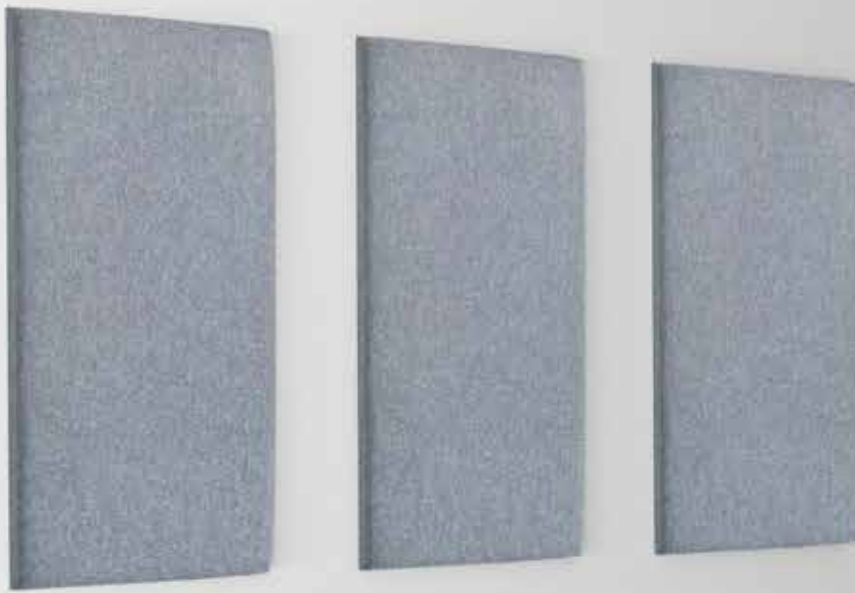



wall mounted (magnetic)
rectangle 604 x 1204 mm



wall mounted (magnetic)
square 604 x 604 mm

1 TYPE

-  Suspended Rectangle / Square
-  Suspended Round
-  Wall Mounted Rectangle / Square

2 SIZE

- HE** 604 x 604 mm
- HR** 604 x 1204 mm
- WE** Ø 700 mm
- Ø 900 mm
- Ø 1200 mm

3 MATERIAL

- 06Q**  QUIET.FELT anthracite melange **QA**
- 120**  QUIET.FELT pebble **QP**
- 070**  QUIET.FELT lime **QL**
- 090**  QUIET.FELT olive green **QO**
- 120**  QUIET.FELT rust **QR**
-  QUIET.FELT blueberry **QU**



EQUIVALENT SOUND ABSORPTION AREA / ABSORBER QUIET.FELT

$$A_{eq}$$

Frequency Hz	100	125	160	200	250	315	400	500	630	800	1000	1250	1600	2000	2500	3150	4000	5000
600x600mm	0,16	0,24	0,40	0,64	0,74	0,83	0,94	1,02	1,08	1,09	1,07	1,08	1,04	1,02	1,00	1,01	1,02	1,03
600x1200mm	0,15	0,26	0,41	0,63	0,75	0,84	0,95	1,03	1,09	1,10	1,08	1,08	1,05	1,02	1,00	1,02	1,03	1,03
Ø 900mm	0,03	0,07	0,25	0,37	0,42	0,52	0,53	0,69	0,81	0,89	1,06	1,1	1,2	1,21	1,26	1,25	1,23	1,22

RECOMMENDED NUMBER OF PANELS

panel 600x1200mm	2x	4x	6x	8x	12x	15x
panel 600x600mm	4x	8x	12x	16x	24x	30x
Ø 700mm	4x	8x	12x	16x	24x	30x
Ø 900mm	2-3x	4-5x	6-7x	9x	13-14x	17x
Ø 1200mm	1-2x	2-3x	4x	5-6x	8x	10x
small rooms < 15 m ²	noticeable	good	very good	excellent		
medium rooms < 20 m ²		noticeable	good	very good	excellent	
large rooms < 35 m ²		noticeable	noticeable	good	very good	excellent

ACOUSTIC PANEL

ISO 11654: Class A, $\alpha_w = 1,00$

EN 13501-1: B-s2,d0

For exact planning contact your local acoustic physicist.

MATERIAL OPTIONS



ANTHRACITE MELANGE

PEBBLE

BLUEBERRY

RUST

LIME

OLIVE GREEN

available as stand-alone panel and for sinus.quiet, quadro.quiet, p.40.quiet, pure 3.quiet

FARBKARTEN | GEHÄUSE & KABEL

COLOUR CHARTS | HOUSING & CABLES



Standard - Ausführung: Transparentes Einspeiskabel | *Standard version: Transparent suspension cable*

Optionale Ausführung | *Optional version:*

Einspeiskabel
Suspension cable

1750 mm
5x0,75 mm²

▷ white	*-EIN-WHITE
▶ black	*-EIN-BLACK
◀ red	*-EIN-RED
▷ iron	*-EIN-IRON
▶ gold	*-EIN-GOLD
▷ silver	*-EIN-SILVER



RAL NACH WAHL | OPTIONALE GEHÄUSEFARBEN

RAL OF YOUR CHOICE | OPTIONAL HOUSING COLOURS



RAL 1001	RAL 1003	RAL 1004	RAL 1013	RAL 1014	RAL 1015	RAL 1016	RAL 1018	RAL 1019	RAL 1021
RAL 1023	RAL 1035	RAL 1036	RAL 2000	RAL 2001	RAL 2003	RAL 2008	RAL 2009	RAL 3000	RAL 3002
RAL 3003	RAL 3009	RAL 3011	RAL 3013	RAL 3016	RAL 3018	RAL 3020	RAL 3031	RAL 3032	RAL 3033
RAL 4005	RAL 4010	RAL 4011	RAL 4012	RAL 5002	RAL 5004	RAL 5010	RAL 5012	RAL 5013	RAL 5018
RAL 5023	RAL 5024	RAL 5025	RAL 5026	RAL 6013	RAL 6014	RAL 6017	RAL 6018	RAL 6019	RAL 6027
RAL 6034	RAL 7001	RAL 7004	RAL 7006	RAL 7011	RAL 7012	RAL 7013	RAL 7015	RAL 7016	RAL 7021
RAL 7022	RAL 7024	RAL 7030	RAL 7031	RAL 7032	RAL 7035	RAL 7037	RAL 7038	RAL 7039	RAL 7043
RAL 7044	RAL 7047	RAL 7048	RAL 8003	RAL 8011	RAL 8012	RAL 8016	RAL 8017	RAL 8019	RAL 8024
RAL 8024	RAL 8029	RAL 9001	RAL 9002	RAL 9011	RAL 9017	RAL 9022			
							Gunnery GREY	Capital COPPER	Glaring GOLD

FARBKARTEN | RASTER, MASKEN & TUBI
COLOUR CHARTS | LOUVRES, MASKS & TUBES



- |
 - |
 - |
 - |
 - |
 - |
 - |
 - |
 - |
 - |
 - |
- | | | | | | | | | | | |
|---------------|---------------|-----------------|-------------------------------|--------------------|-----------------|----------------------|-------------------|-----------------|----------------------|---------------|
| white
9019 | black
9005 | glaring
gold | high-gloss
black
chrome | high-gloss
gold | gunnery
grey | high-gloss
copper | capital
copper | silver
matte | high-gloss
silver | PLF
Raster |
|---------------|---------------|-----------------|-------------------------------|--------------------|-----------------|----------------------|-------------------|-----------------|----------------------|---------------|

FARBKARTEN | DIFFUSOREN & OPTIKEN

COLOUR CHARTS | DIFFUSERS & OPTICS



FARBKARTEN | QUIET-PRODUKTLINIE: ABSORBER

COLOUR CHARTS | QUIET PRODUCT LINE: ABSORBERS

ORGANOID®



WILDSPITZE
[vɪltʃpɪtsə]



WOLLÄ
[ˈvɔlə]

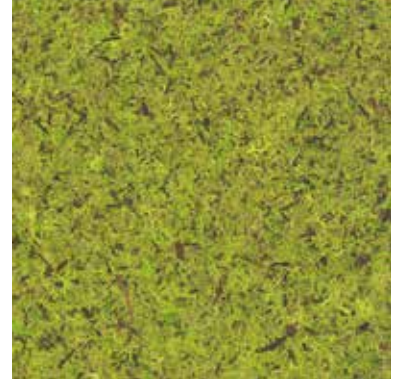

MOUS
[ˈməʊz]

FARBKARTEN | QUIET-PRODUKTLINIE: ABSORBER

COLOUR CHARTS | QUIET PRODUCT LINE: ABSORBERS

FELT.QUIET



ANTHRACITE MELANGE



PEBBLE



BLUEBERRY



RUST



LIME

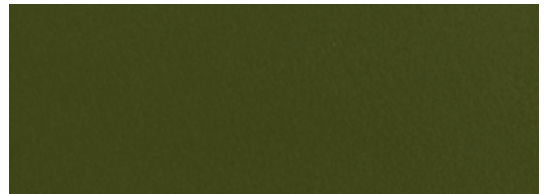

OLIVE GREEN

WICHTIGE HINWEISE

Dieser Katalog richtet sich ausschliesslich an gewerbliche Kunden. Die in diesem Katalog angegebenen Werte sind Bemessungswerte und unterliegen produktionsbedingten Toleranzen*. Alle angeführten Angaben – insbesondere Grössen-, Material-, Farb- und technische Angaben – entsprechen dem Stand zum Zeitpunkt des Drucks und dienen ausschliesslich zur Information. Der Herausgeber haftet nicht für Satz- und Druckfehler sowie für Abweichungen der Produkte von Abbildungen und Angaben. PLANLICHT behält sich vor, jederzeit ohne Ankündigung Änderungen an Produkten vor zu nehmen. Es gelten die Allgemeinen Geschäftsbedingungen der planlicht GmbH & Co KG, die unter WWW.PLANLICHT.COM/AGB-LANDING/ eingesehen werden können.

Technische Kennzahlen, angeführte Werte und die Piktogrammleiste betreffen zumindest einen aber nicht zwingend alle Artikel der jeweiligen Leuchtenfamilie, exakte Angaben je Artikel finden Sie im Online-Katalog bzw. in PLANLICHT-Verkaufsbelegen und Datenblättern.

WEEE-Reg.-Nr. DE 54728470

* Leistung, Lichtstrom und Farbtemperatur unterliegen durch den Einsatz von elektronischen Bauteilen produktionsbedingten Toleranzen. Toleranzen Leistung und Lichtstrom: +/- 10%. Toleranz Farbtemperatur: +/- 150 K. Lichtstrom dynamisch weiss bei 2700 K.

IMPORTANT REMARKS

This catalogue is reserved for professionals only. The values published in this catalogue are rated values, which can slightly change for reasons related to the production process. The published data such as dimensions, materials, colours and technical data are valid at time of printing, and exclusively provided for informational purposes. The editor takes no responsibility for typographical and print errors, as well as for any differences in the products, pictures and data. PLANLICHT reserves the right to change the products at any time and without any notice. The Terms and Conditions of planlicht GmbH & Co KG (available on WWW.PLANLICHT.COM/AGB-LANDING/) shall apply.*

Key technical specifications, listed values as well as the pictogram bar relate to at least one but not necessarily all items of the respective luminaire family, exact details for each item can be found in the online web catalogue or in PLANLICHT sales documents and data sheets.

** The power output, luminous flux and colour temperature can be slightly different due to specific electronic components used in the manufacturing process. The power output and luminous flux can differ by +/- 10%. The colour temperature can differ by +/- 150K. Luminous flux dynamic white at 2700K.*

RELEVANTE INFORMATIONEN AUF EINEN BLICK

- Allgemeine Geschäfts- & Lieferbedingungen – Die Grundlage unserer Zusammenarbeit
- Garantie 66 – Das Qualitätsversprechen im Detail
- Technische Hinweise – Wichtige Informationen zur Planung
- Produktseiten – So lesen Sie unsere Übersichten
- Artikelnummer – Die Logik hinter dem Code
- Piktogramme – Die Symbole und ihre Bedeutung



RELEVANT INFORMATION AT A GLANCE

- Terms & Conditions – The Basis of Our Cooperation
- Guarantee 66 – Our Commitment to Quality
- Technical Notes – Essential Guidance for Planning
- Product Pages – How to Read Our Overviews
- Article Number – The Logic Behind the Code
- Pictograms – The Meaning Behind the Symbols

IMPRINT

Publisher: planlicht GmbH & Co. KG, Vomp
Creative Concept: Katrin Atzinger
Graphic Design: Beatrice Praxmarer, Christoph Höflinger
Print: Kraller Druck, Vahrn (BZ)
© 2026



6134 Vomp, Austria, Au 25
Tel. +43-5242-71608, Fax +43-5242-71283
info@planlicht.com
WWW.PLANLICHT.COM



AKUSTIK

ACOUSTIC

WWW.PLANLICHT.COM