

PROFIL- & SYSTEMLEUCHTEN



PROFILE & SYSTEM LUMINAIRES

PROFIL- & SYSTEMLEUCHTEN |
PROFILE & SYSTEM LUMINAIRES

DIE PLANLICHT-PROFIL- & SYSTEMLEUCHTEN IM ÜBERBLICK

PLANLICHT PROFILE & SYSTEM LUMINAIRES AT A GLANCE

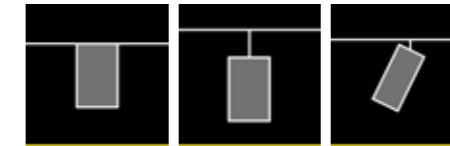

P.BRIGHT

BRILLIANT. EFFICIENT. VERSATILE.

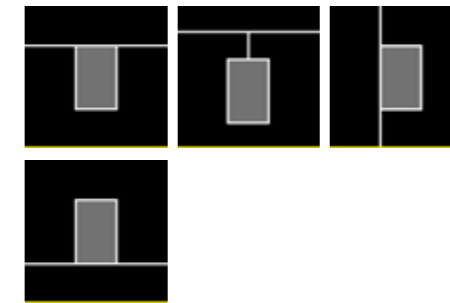

P.THIRTY

SMALL BUT POWERFUL

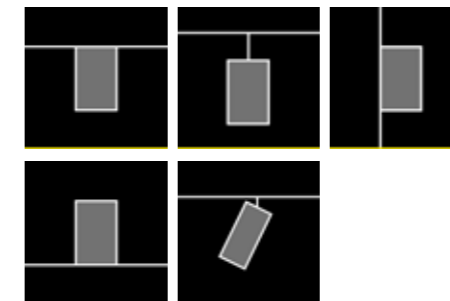

P.FORTY

LIGHTING TECHNOLOGY MEETS
EYE COMFORT

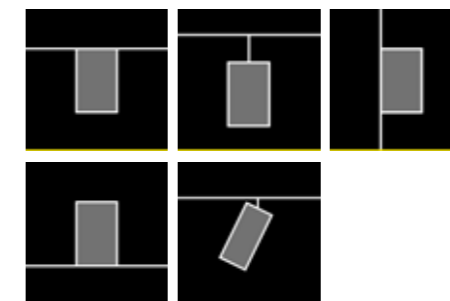
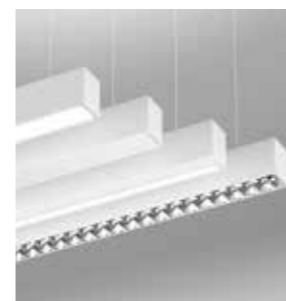

PURE 3

SHAPELY FLEXIBILITY

PURE 2 IP54

excluding 3-Phase Track

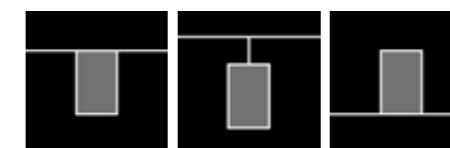
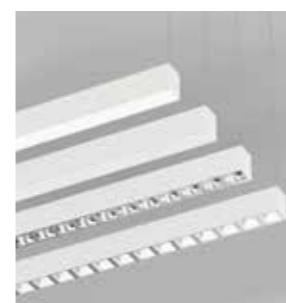

QUADRO

DESIGN MEETS PERFORMANCE

P.BRIGHT | BRILLIANT. EFFICIENT. VERSATILE

Als Einzelleuchte im Profilsystem oder als modulares Lichtbandsystem lässt sie sich individuell anpassen. Mit sieben Längen und einem Ecksegment ermöglicht p.bright maßgeschneiderte Lichtlösungen – von durchgängigen Lichtbändern bis zu einzigartigen Lichtkonfigurationen, die sich nahtlos in anspruchsvolle Architektur integrieren lassen.

Whether as an individual luminaire in the profile system or as a modular system, it can be tailored to meet your needs. With seven lengths and one corner segment, p.bright enables custom lighting solutions, from continuous linear lighting to unique configurations seamlessly integrated into sophisticated architecture.

SURFACE

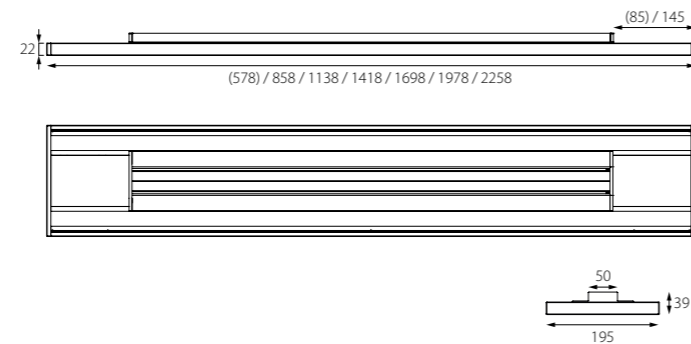
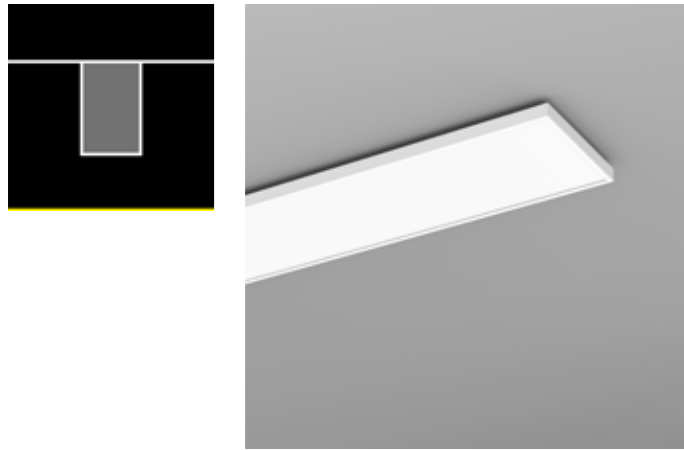

3-PHASE TRACK LIGHT

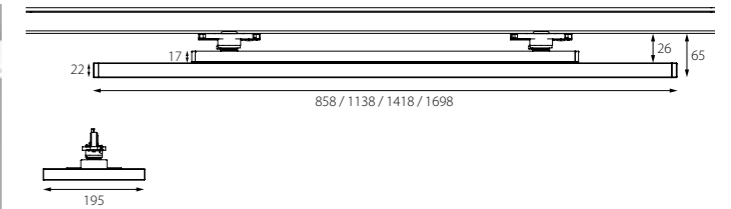
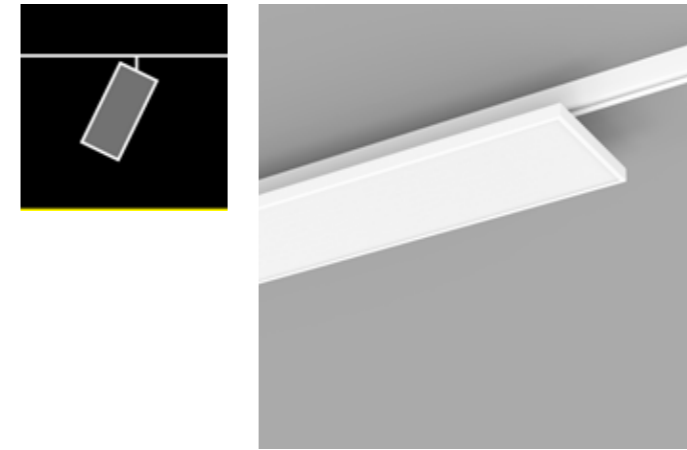

PENDANT

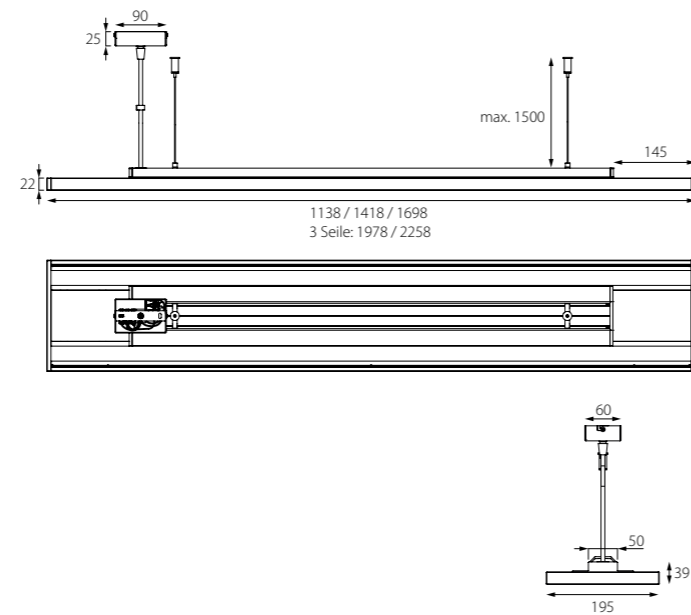
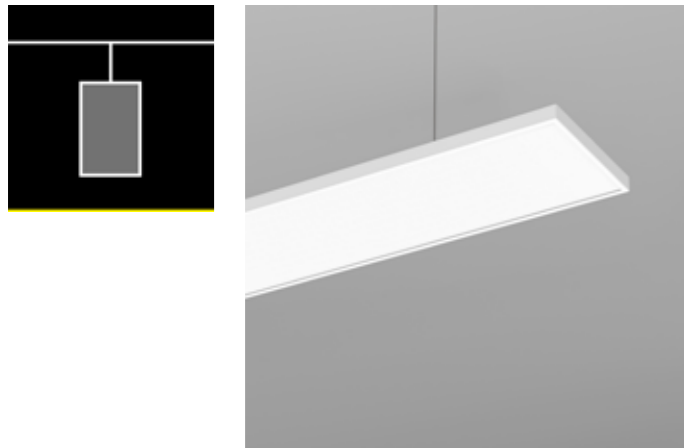

INSPIRATION

Produkt: p.bright

INSPIRATION

Product: p.bright

P.THIRTY | SMALL BUT POWERFUL

p.thirty ist die kleinste der PLANLICHT-Profilleuchten und besticht durch eine minimalistische Bauform und große Variabilität. Starke Lichtleistung, hoher Sehkomfort und ein integriertes Vorschaltgerät verstehen sich dabei natürlich von selbst.

p.thirty is the smallest of the PLANLICHT profile luminaires and impresses with a minimalistic design and great variability. Great performance, high eye comfort and an integrated driver go without saying.



SURFACE

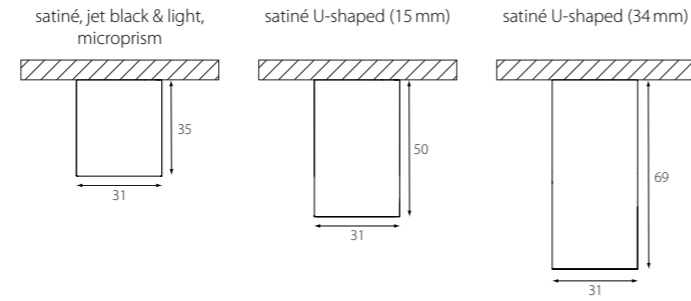
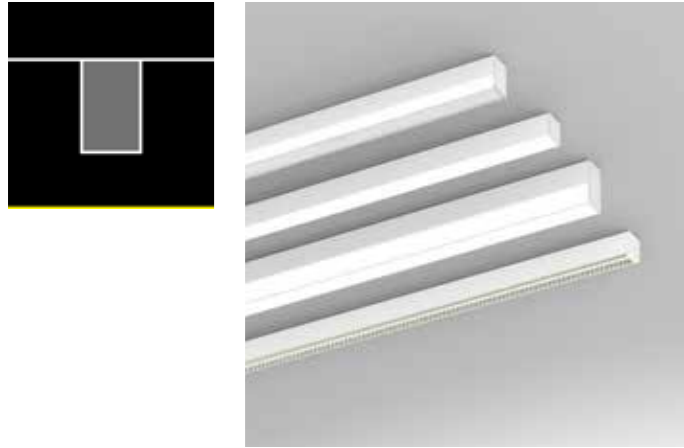

SINUS P.THIRTY

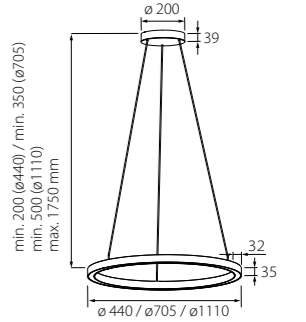

PENDANT

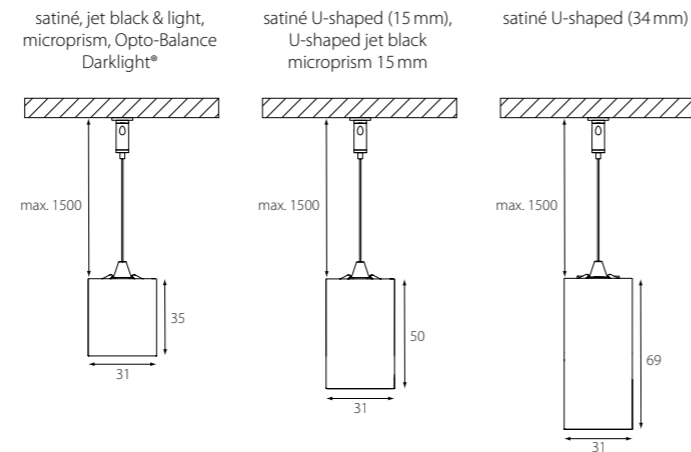
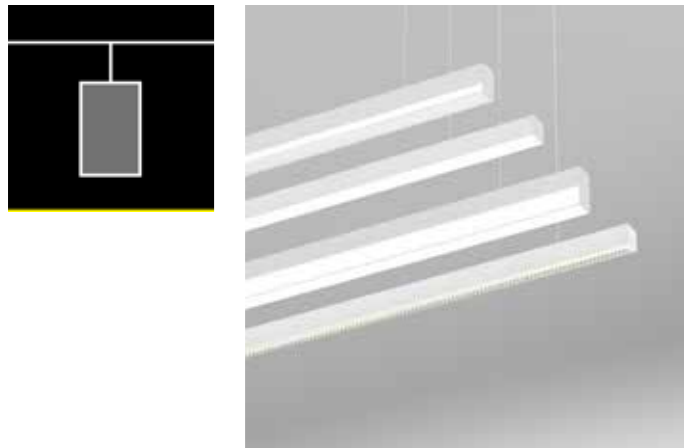

WALL

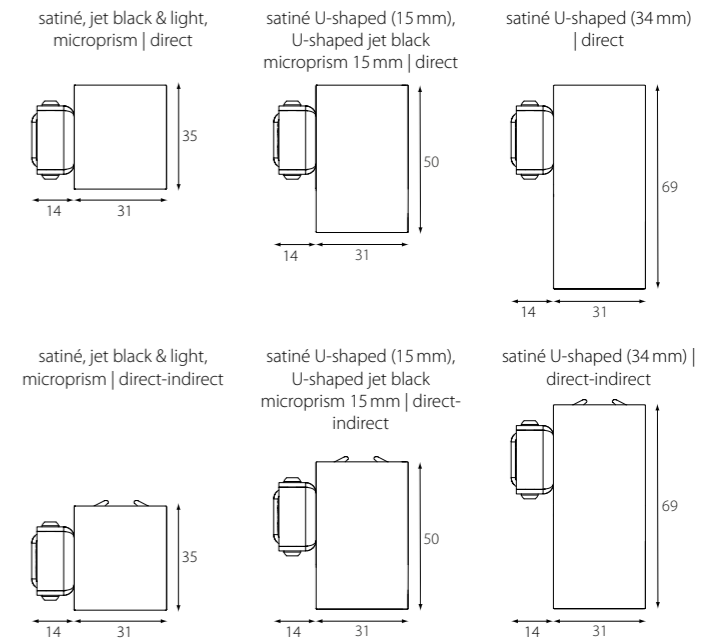

P.THIRTY OFFICE SPECIAL

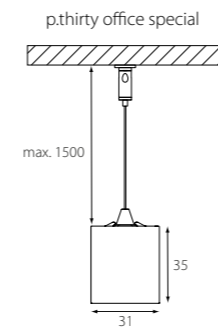
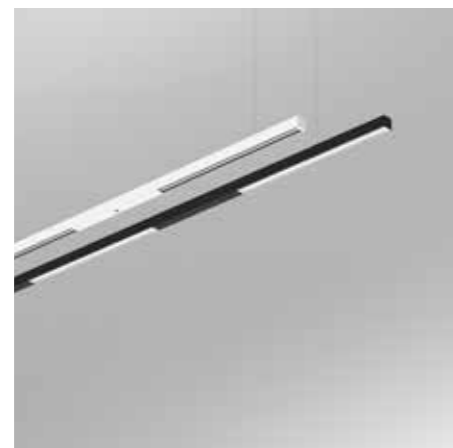

RECESSED

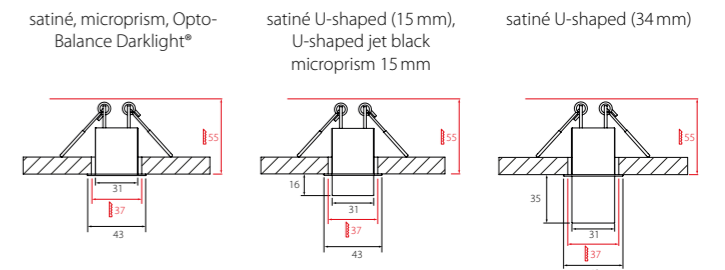
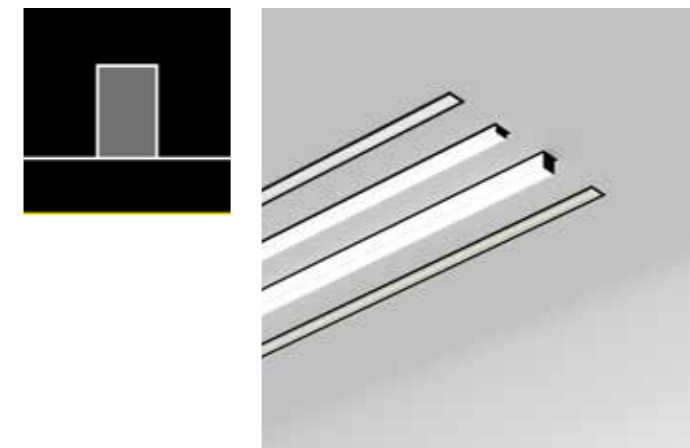

FLOOR LAMP

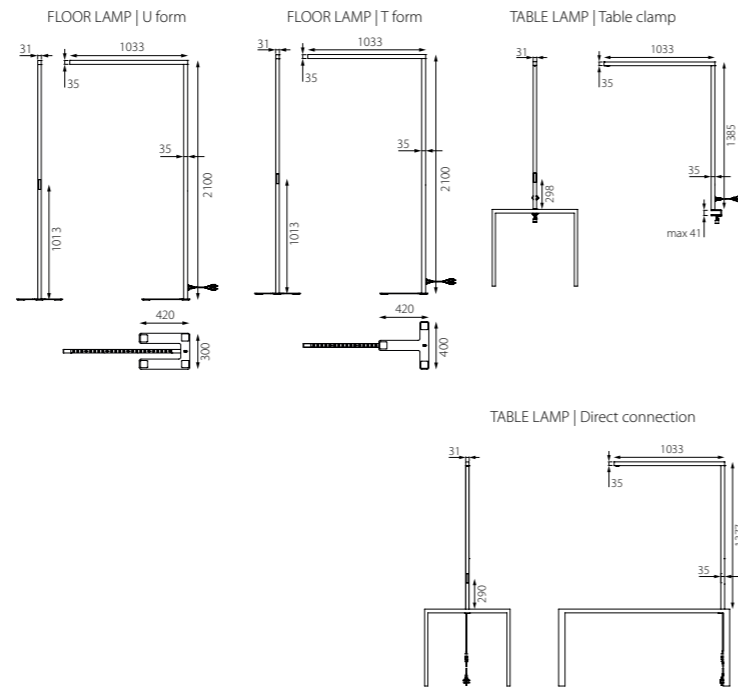
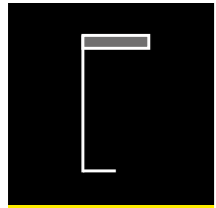

RATSSAAL WEINSBERG | DEUTSCHLAND

Produkte: p.thirty, pure 3
 Foto: © Fotografie Dietmar Strauß, Besigheim | Architekten: MATTES RIGLEWSKI
 WAHL Architekten, Lichtplanung: Designbüro Wolfgang Strümpfner

RATSSAAL WEINSBERG | GERMANY

Products: p.thirty, pure 3
 Photo: © Fotografie Dietmar Strauß, Besigheim | Architects: MATTES RIGLEWSKI
 WAHL Architekten, Light planning: Designbüro Wolfgang Strümpfner



INSPIRATION

Produkt: p.thirty

INSPIRATION

Product: p.thirty

P.FORTY | LIGHTING TECHNOLOGY MEETS EYE COMFORT

p.forty ist die Meisterin der Montagearten: kaum eine Anbringungsart ist ihr fremd und so sind ihre Einsatzgebiete vielfältig. Die dezente Profil-
leuchte mit hohem Sehkomfort ist zudem mit einer Vielzahl an unterschiedlichen Diffusoren erhältlich.

p.forty is the master of mounting types: hardly any mounting method isn't applicable and so its areas of application are diverse. The discreet profile luminaire with high visual comfort is also available with a variety of different diffusers.



SURFACE

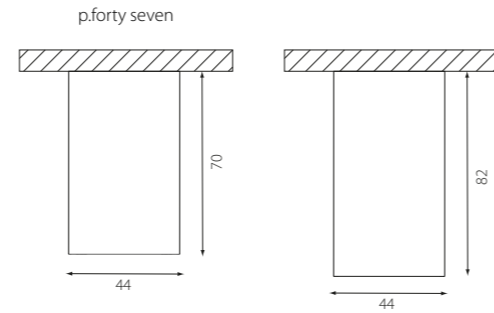

P.FORTY SHAPES

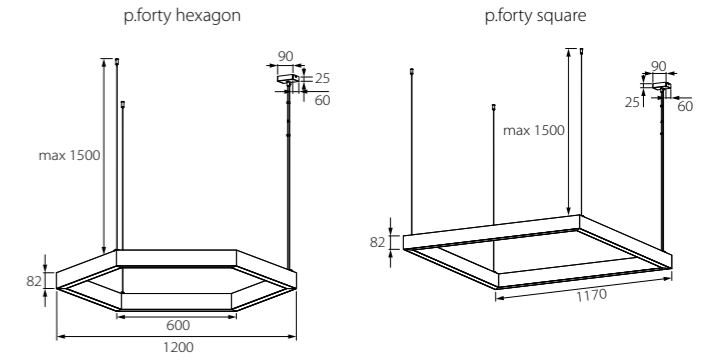

P.FORTY SHAPES

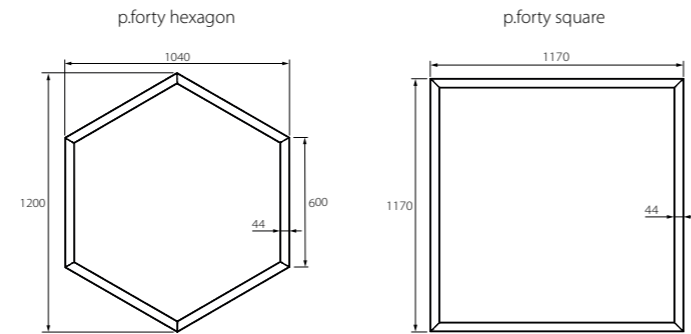

P.FORTY.QUIET

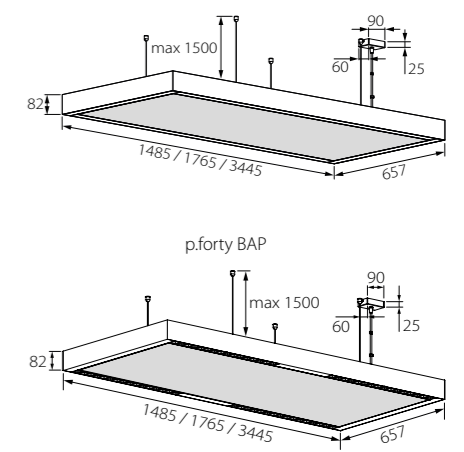

PENDANT

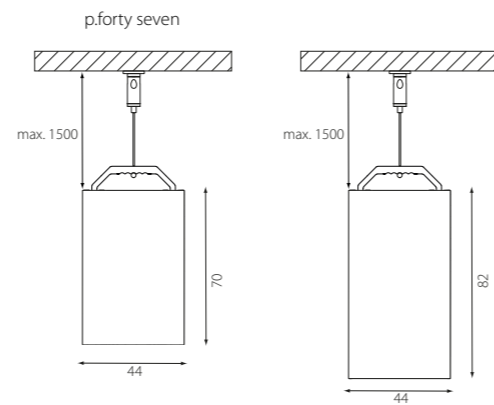

WALL

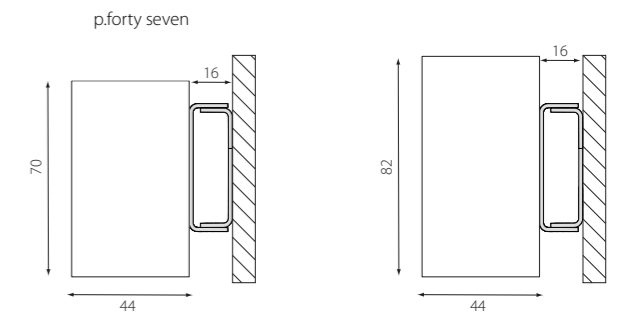

RECESSED

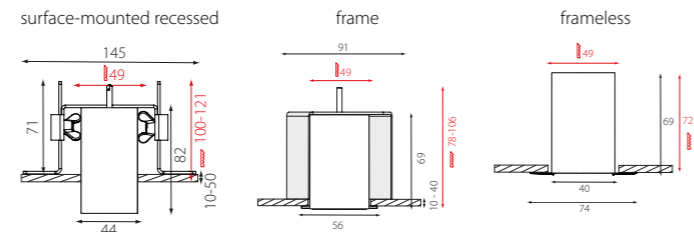
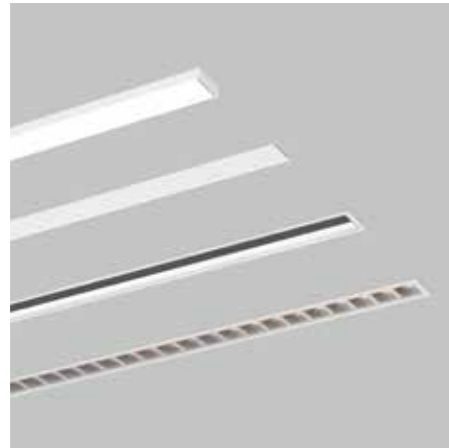
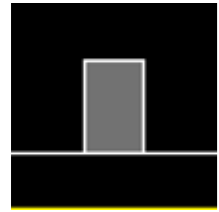

3-PHASE-TRACK LIGHT

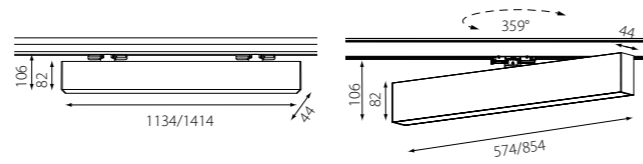
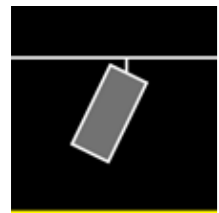

IGZ CAMPUS FALKENBERG | DEUTSCHLAND

Produkt: p.forty
Foto: © David Franck, Ostfildern | Architekten: J. Mayer H. und Partner, Architekten MBB

IGZ CAMPUS FALKENBERG | GERMANY

Product: p.forty
Photo: © David Franck, Ostfildern | Architects: J. Mayer H. und Partner, Architekten MBB

PURE 3 | SHAPELY FLEXIBILITY

Bei pure 3 wird Flexibilität großgeschrieben: Die Profileuchte kann modular mit den speziellen Linienvierbindern nicht nur als endloses Band kombiniert werden, sondern es gibt sich auch eine stufenlose Vielfalt an Gehrungswinkeln. Ob als L oder T, als Viereck oder mehrmals um die Ecke, Homogenität und Effizienz stehen immer im Vordergrund.

Flexibility is a top priority with pure 3: The profile luminaire can be combined modularly with the special line connectors not only as an endless strip, but there is also a stepless variety of mitre angles. Whether as an L or a T, as a square or several times around the corner, homogeneity and efficiency are always in the foreground.



SURFACE

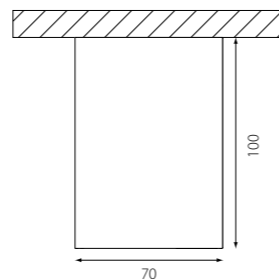
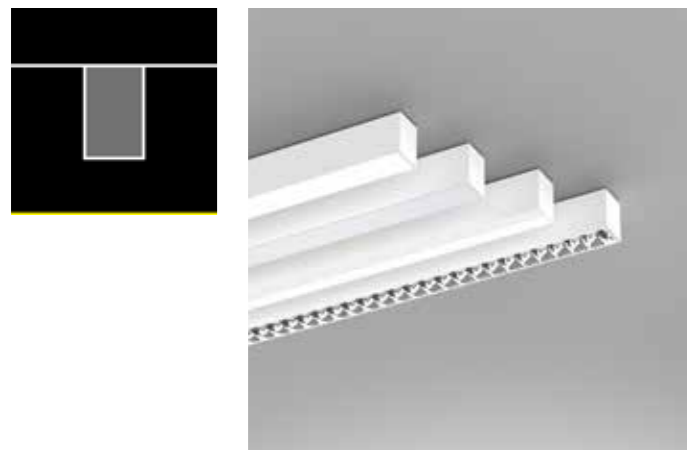

PENDANT

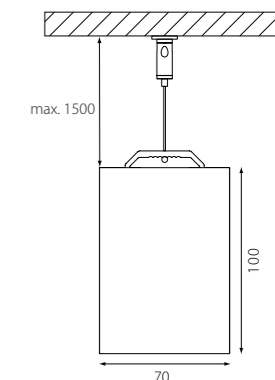
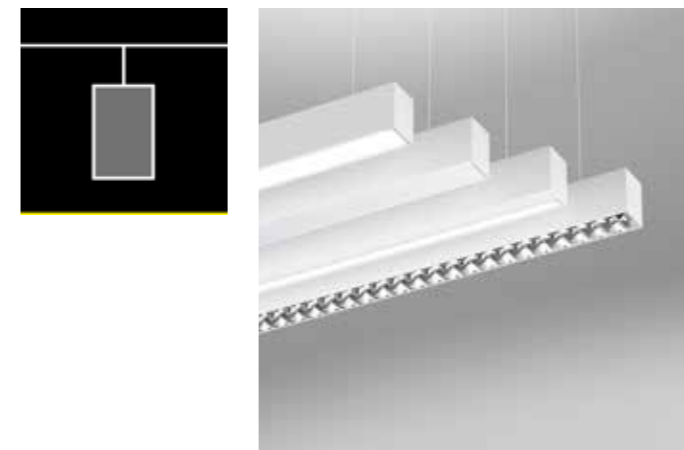

PURE 3 SHAPES

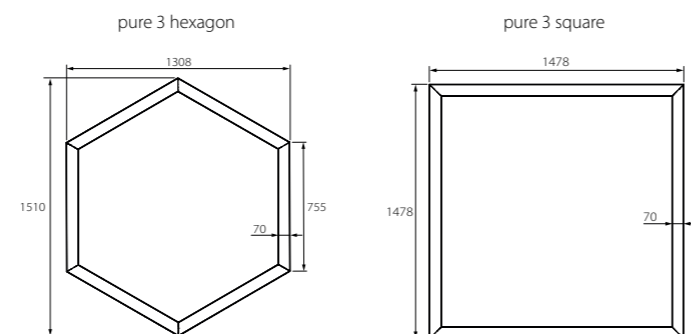

PURE 3 SHAPES

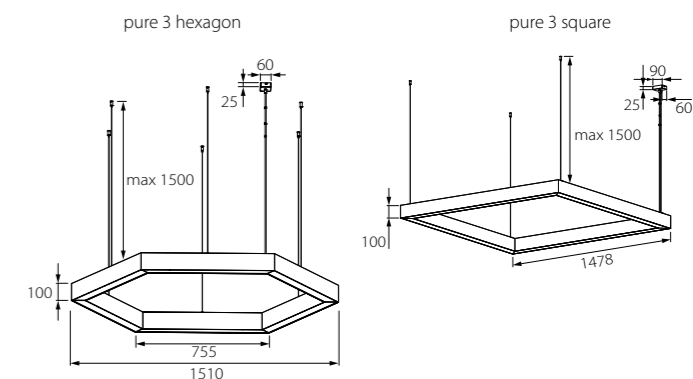

PURE 3 TRIFLECT

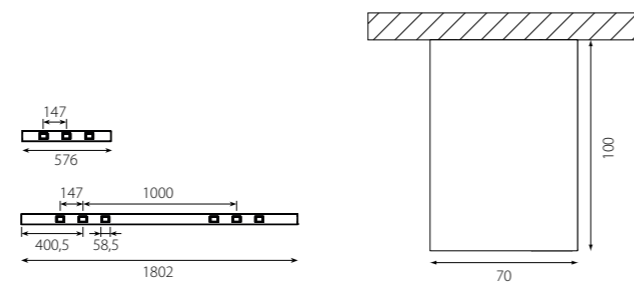
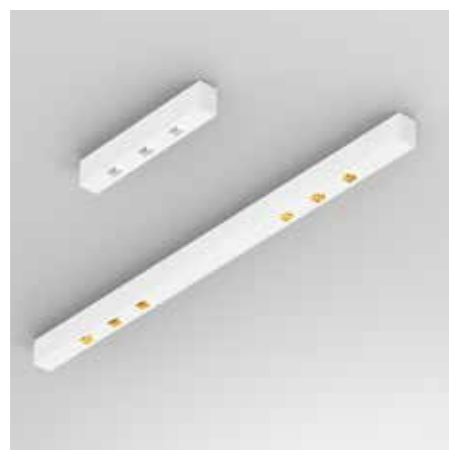

PURE 3 TRIFLECT

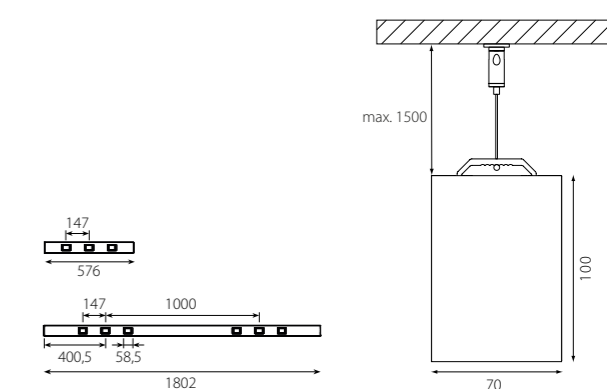

PURE 3.QUIET

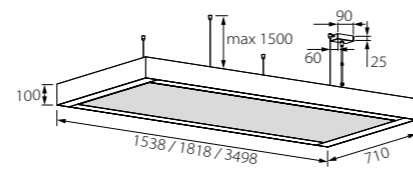

3-PHASE TRACK LIGHT

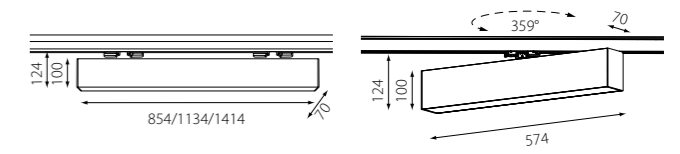
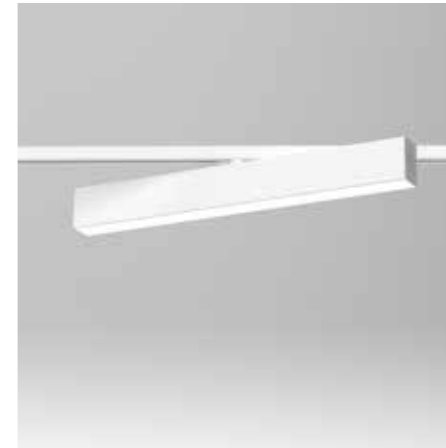
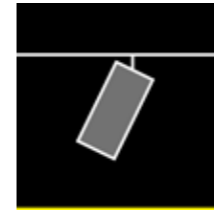

WALL

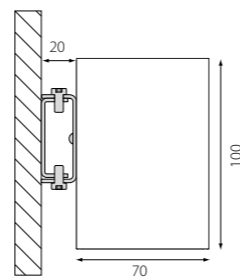

RECESSED | FRAME

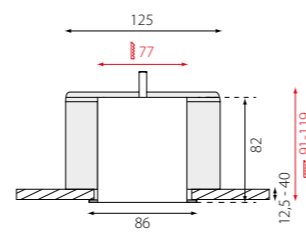
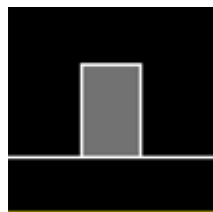

**NEUBAU KINDERGARTEN IN POTSDAM
HERMANNSWERDER | DEUTSCHLAND**

Produkt: pure 3
Foto: © Robert Gommlich Fotografie | Architekten: Architekturbüro Raum und Bau GmbH

**NEUBAU KINDERGARTEN IN POTSDAM
HERMANNSWERDER | GERMANY**

Produkt: pure 3
Photo: © Robert Gommlich Fotografie | Architects: Architekturbüro Raum und Bau GmbH



LAHDEN LUKIO GAUDIA | LAHTI, FINNLAND

Produkt: pure 3

LAHDEN LUKIO GAUDIA | LAHTI, FINNLAND

Product: pure 3



**NEUBAU GEMEINSCHAFTSSCHULE CAMPUS CORDIS
IN DRESDEN | DEUTSCHLAND**

Produkt: pure 3
Fotos: © Robert Gommlich Fotografie | Planer: RBZ Generalplanungs-
gesellschaft, Raum und Bau, AGZ Zimmermann Architekten GmbH

**NEUBAU GEMEINSCHAFTSSCHULE CAMPUS CORDIS
IN DRESDEN | GERMANY**

Product: pure 3
Photos: © Robert Gommlich Fotografie | Planning: RBZ Generalplanungs-
gesellschaft, Raum und Bau, AGZ Zimmermann Architekten GmbH



SURFACE

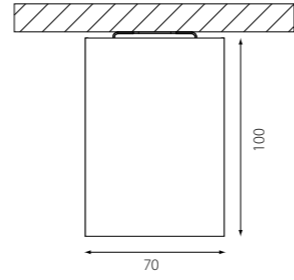

RECESSED

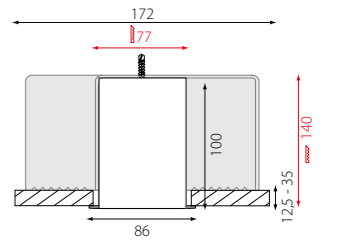

PENDANT

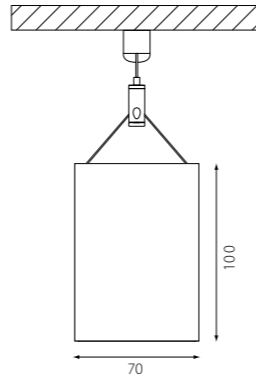
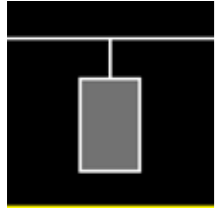

WALL

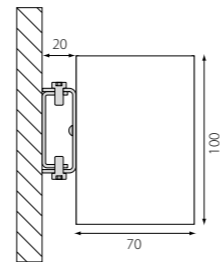

QUADRO | DESIGN MEETS PERFORMANCE

Eine leistungsstarke, optisch ansprechende Leuchte perfekt geeignet für den Einsatz im Büro – das trifft auf quadro zu. Die Profileuchte weist ein spezielles Raster-Design auf, das in verschiedenen Effektfarben (u. a. in Metallic-Optik) erhältlich ist, kann aber auch mit verschiedenen Abdeckungen (opaler Diffusor oder mikroprismatisch) geordert werden.

A powerful, visually appealing luminaire perfectly suited for office use – this is true of quadro. The profile luminaire has a special louvre design that is available in various effect colours (including metallic looks), but can also be ordered with different covers (opal diffuser or microprismatic).



SURFACE

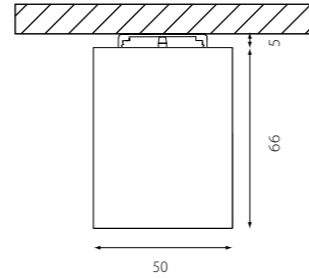
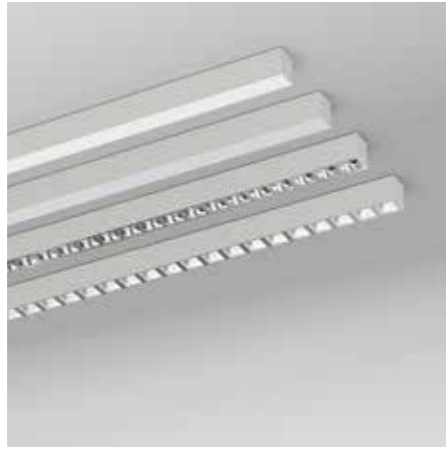
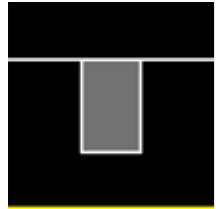

QUADRO.QUIET

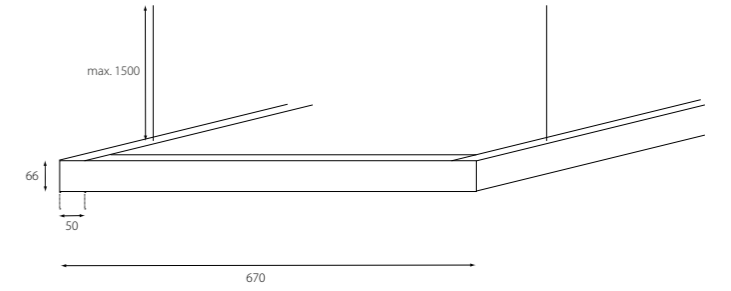

PENDANT

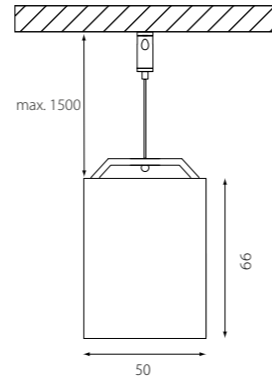
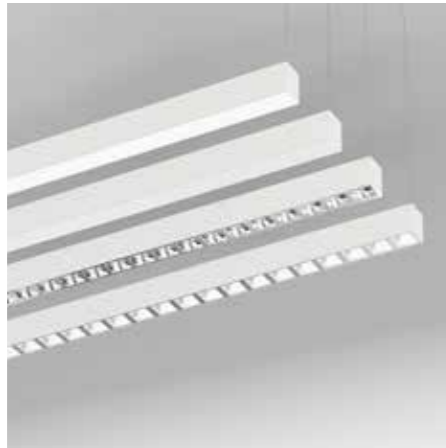
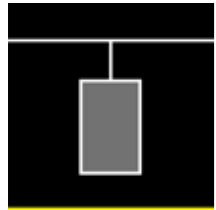

RECESSED

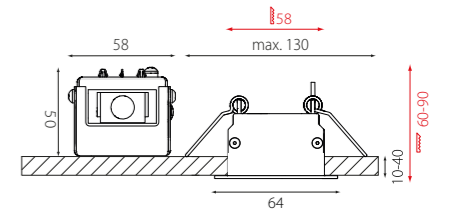
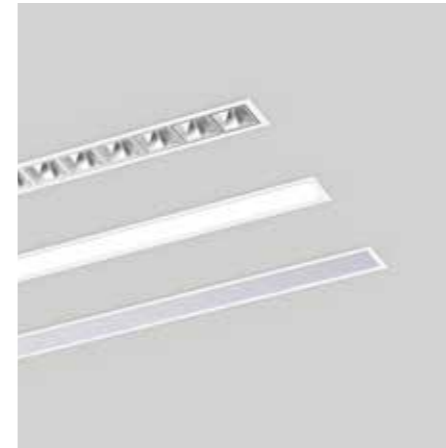

QUADRO OFFICE SPECIAL

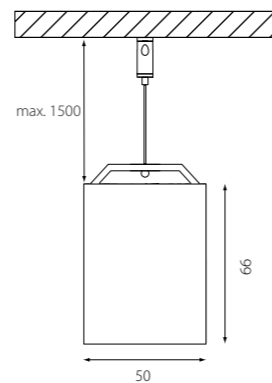



BWF GROUP SHOWROOM | DEUTSCHLAND

Produkt: quadro.quiet

BWF GROUP SHOWROOM | GERMANY

Product: quadro.quiet



INSPIRATION

Produkt: quadro

INSPIRATION

Product: quadro

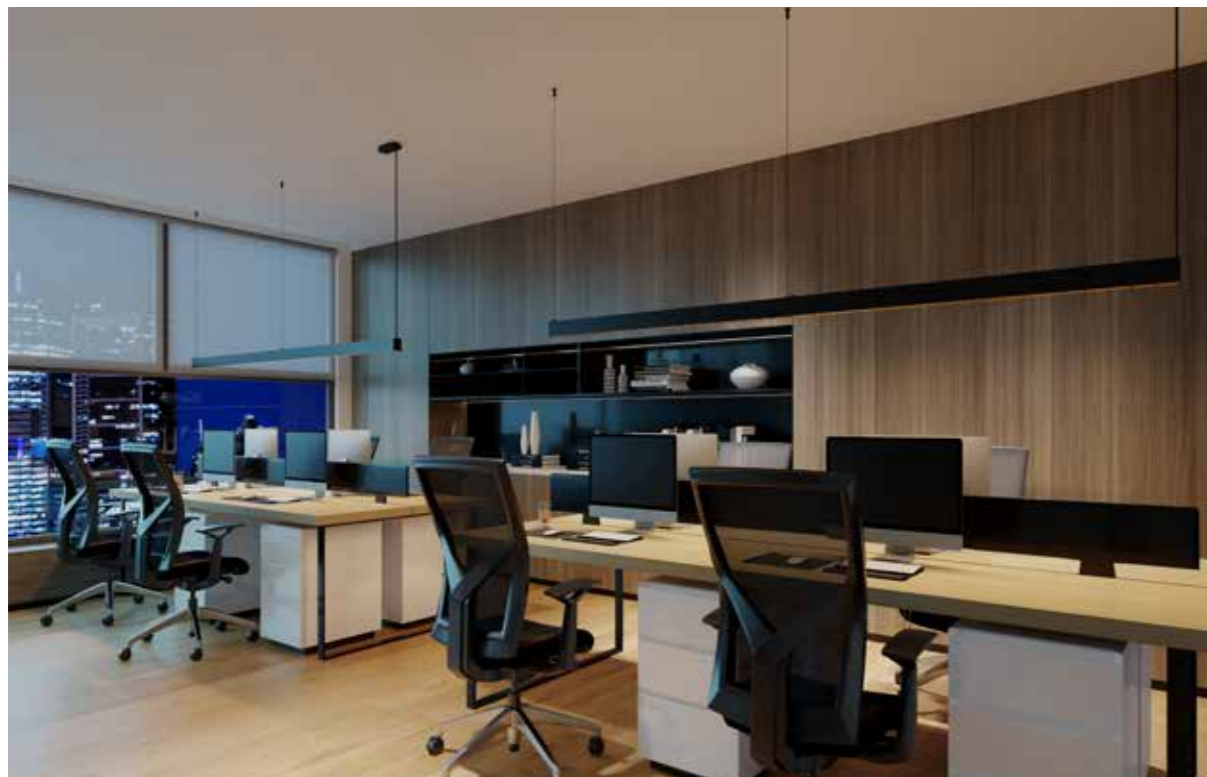

INSPIRATION

Produkt: quadro

INSPIRATION

Product: quadro

INSETS | FÜR PROFIL- & SYSTEMLEUCHTEN

INSETS | FOR PROFILE & SYSTEM LUMINAIRES

Die Leuchten bieten nicht nur durch verschiedene Diffusoren perfekte Lichtqualität – mit unterschiedlichen Insets lassen sich Räume zusätzlich zum Strahlen bringen.

The luminaires not only achieve perfect illumination with a choice of diffusers – they also offer various insets that make spaces truly shine.

ANTO+ | INSET P.FORTY & PURE 3

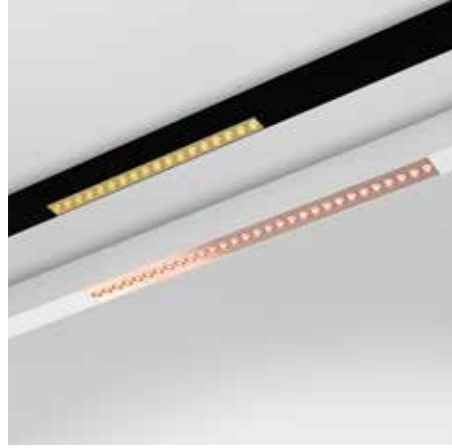

ZENIT XXS | INSET P.THIRTY

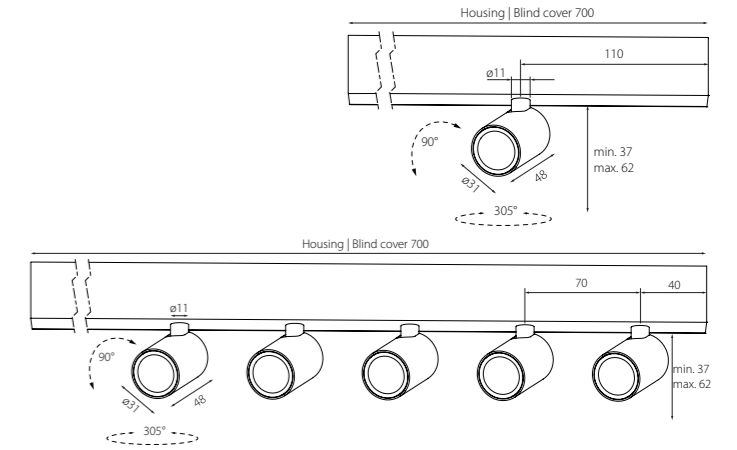

ZENIT XXS | INSET P.BRIGHT

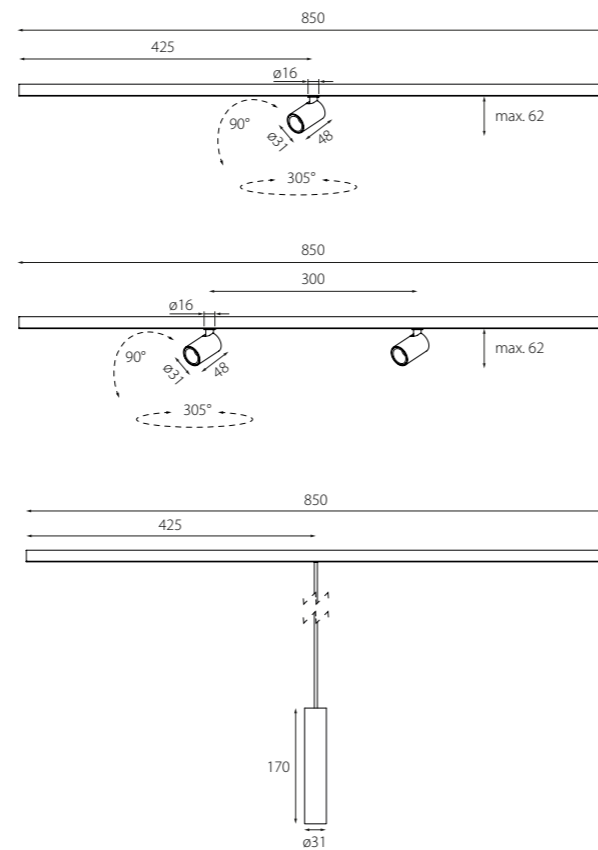

ZENIT XXS | INSET P.FORTY & PURE 3

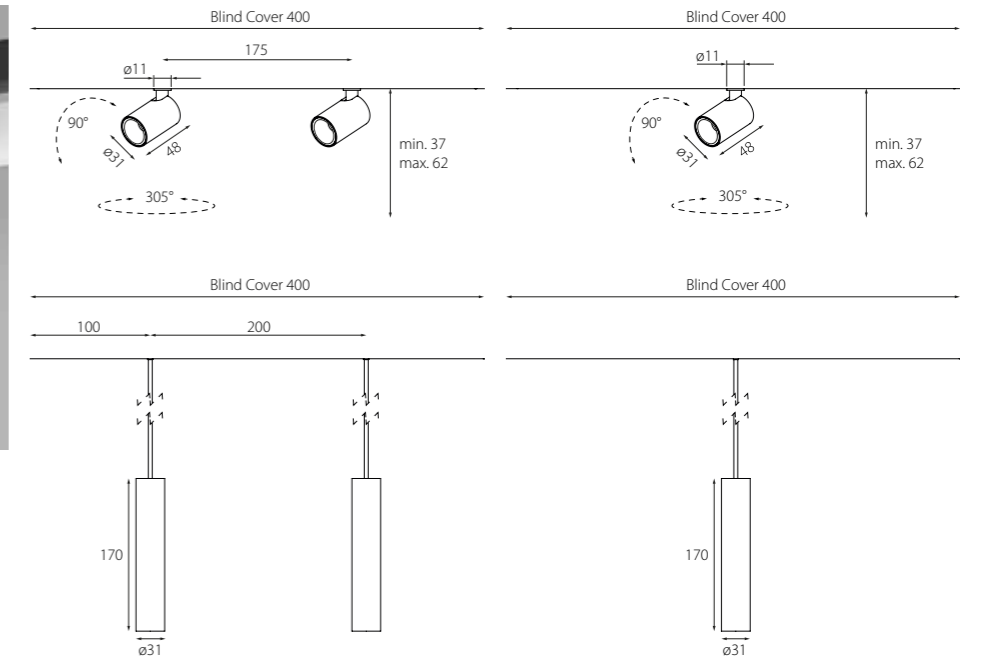
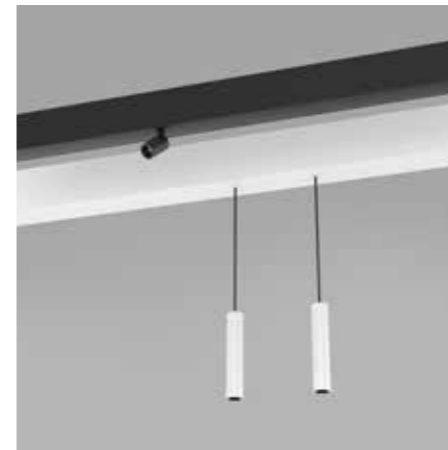

ZENIT XS | INSET PURE 3

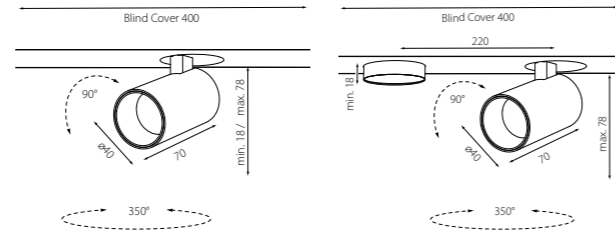

PURE 3 | INSET TRIFLECT

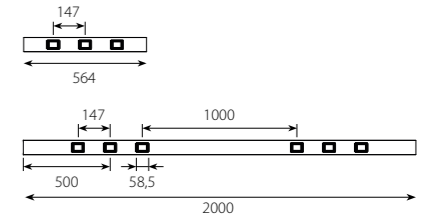

ZENIT S | INSET P.BRIGHT

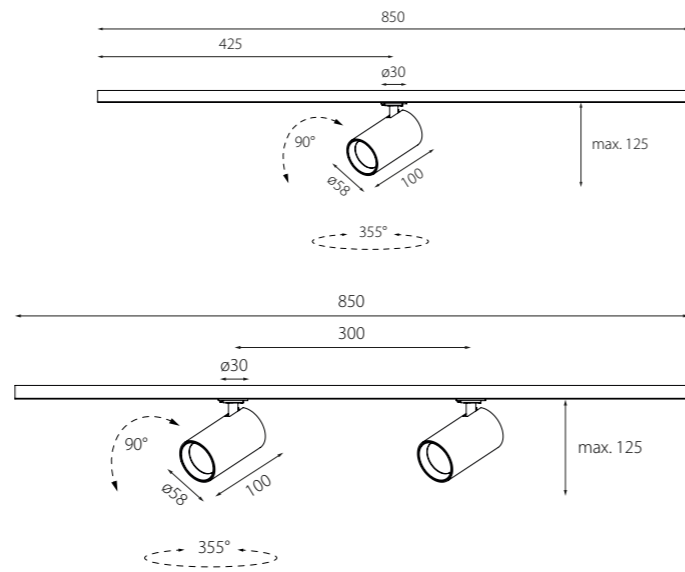

ZENIT S | INSET P.FORTY & PURE 3

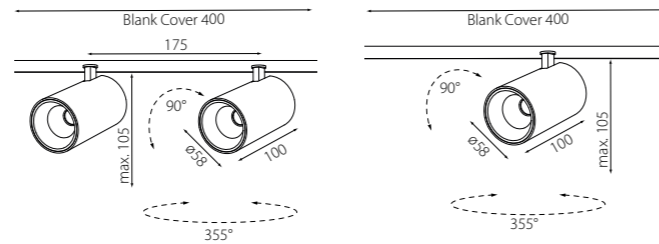

FARBKARTEN

COLOUR CHARTS

DIFFUSOREN

DIFFUSERS



P.FORTY BAP RASTER

P.FORTY BAP LOUVRES

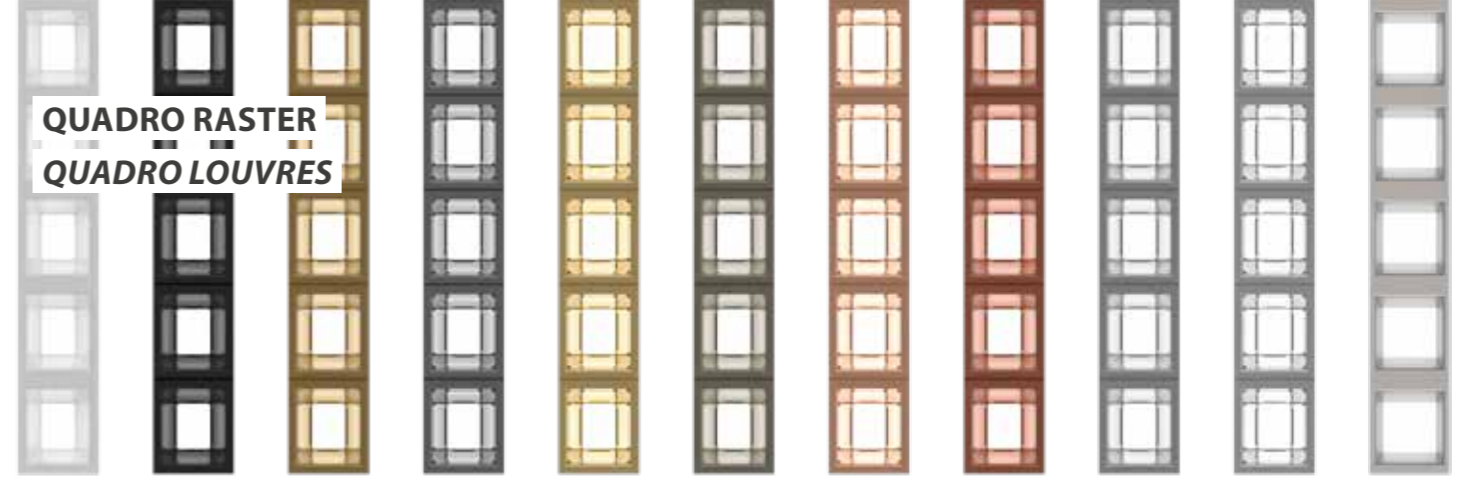

white 9019 black 9005 glaring gold high-gloss black chrome high-gloss gold gunnery grey high-gloss copper capital copper silver matte high-gloss silver PLF

GEHÄUSEFARBEN

HOUSING COLOURS

STANDARD



OPTIONAL



AKUSTIK ABSORBER

ACOUSTIC ABSORBERS

FELT.QUIET

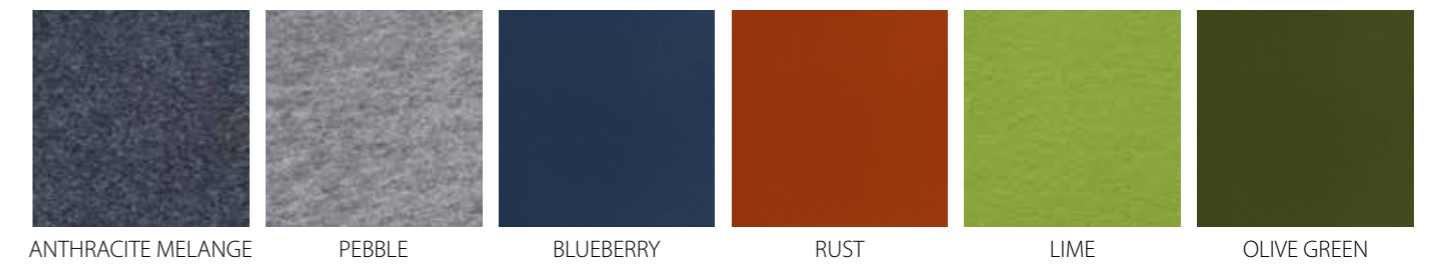

ORGANOID®



**KABELFARBEN
CABLE COLOURS**

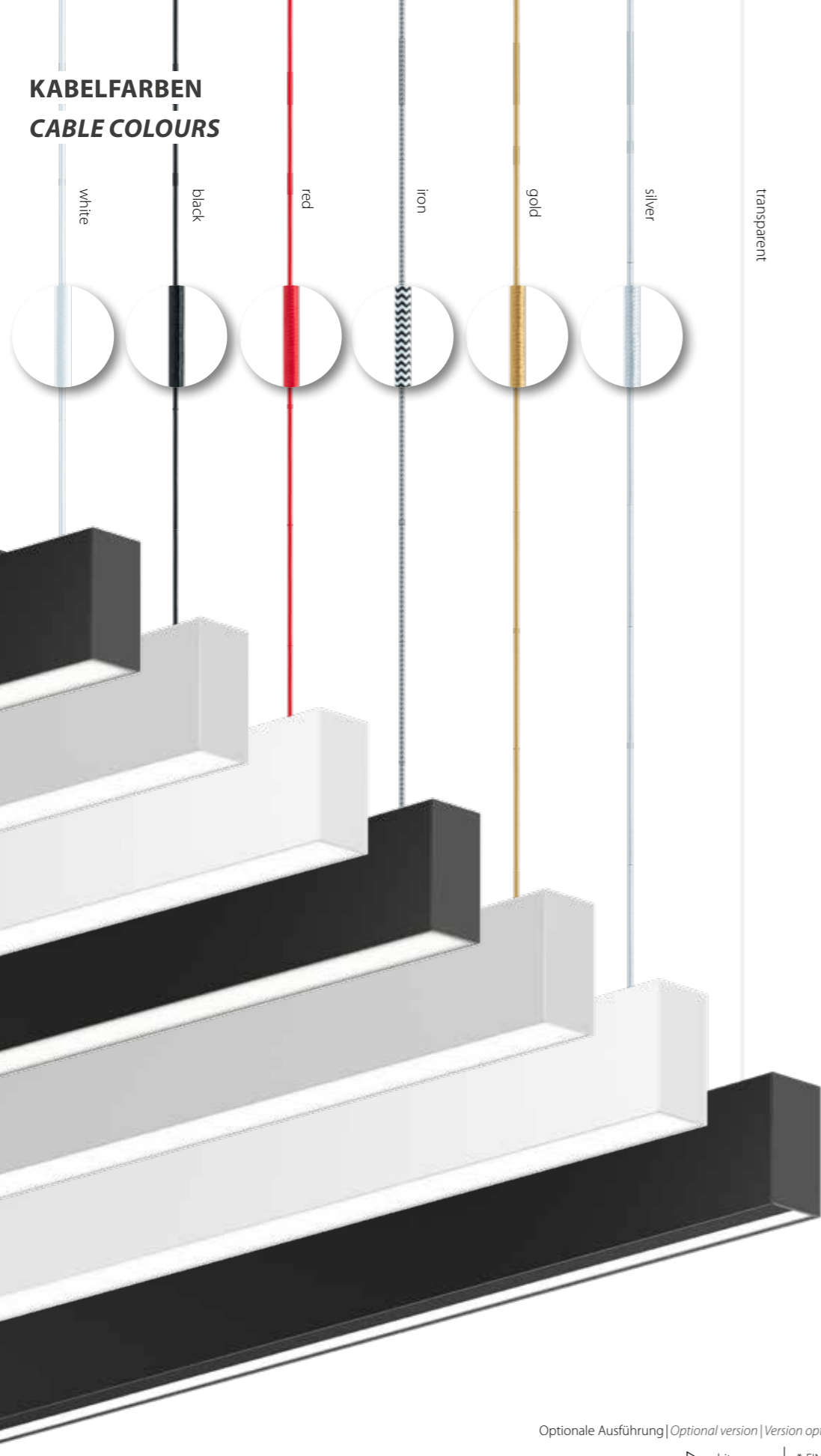







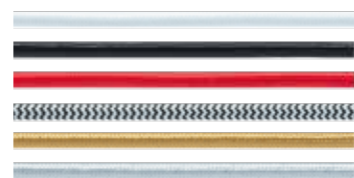









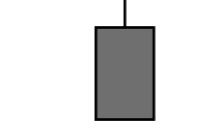





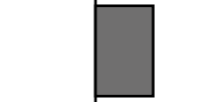



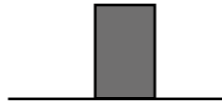

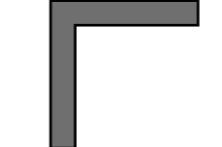

Optionale Ausführung | Optional version | Version optionnelle

▷ white	*-EIN-WHITE
▷ black	*-EIN-BLACK
▷ red	*-EIN-RED
▷ iron	*-EIN-IRON
▷ gold	*-EIN-GOLD
▷ silver	*-EIN-SILVER

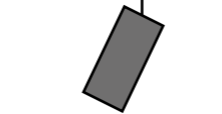
Transparentes Kabel inkludiert (Standard Version)
Transparentes Kabel inkludiert (Standard Version)

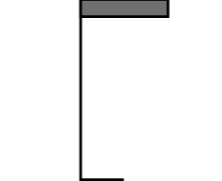

für besondere Anfragen 
special requests

	p.bright	p.forty	p.thirty	pure 3	quadro
					
					
					
					
					
					
					

WICHTIGE HINWEISE

Dieser Katalog richtet sich ausschliesslich an gewerbliche Kunden. Die in diesem Katalog angegebenen Werte sind Bemessungswerte und unterliegen produktionsbedingten Toleranzen*. Alle angeführten Angaben – insbesondere Grössen-, Material-, Farb- und technische Angaben – entsprechen dem Stand zum Zeitpunkt des Drucks und dienen ausschliesslich zur Information. Der Herausgeber haftet nicht für Satz- und Druckfehler sowie für Abweichungen der Produkte von Abbildungen und Angaben. PLANLICHT behält sich vor, jederzeit ohne Ankündigung Änderungen an Produkten vor zu nehmen. Es gelten die Allgemeinen Geschäftsbedingungen der planlicht GmbH & Co KG, die unter WWW.PLANLICHT.COM/AGB-LANDING/ eingesehen werden können.

Technische Kennzahlen, angeführte Werte und die Piktogramme betreffen zumindest einen aber nicht zwingend alle Artikel der jeweiligen Leuchtenfamilie, exakte Angaben je Artikel finden Sie im Online-Katalog bzw. in PLANLICHT-Verkaufsbelegen und Datenblättern.

WEEE-Reg.-Nr. DE 54728470

* Leistung, Lichtstrom und Farbtemperatur unterliegen durch den Einsatz von elektronischen Bauteilen produktionsbedingten Toleranzen. Toleranzen Leistung und Lichtstrom: +/- 10%. Toleranz Farbtemperatur: +/- 150 K. Lichtstrom dynamisch weiss bei 2700 K.

RELEVANTE INFORMATIONEN AUF EINEN BLICK

- Allgemeine Geschäfts- & Lieferbedingungen – Die Grundlage unserer Zusammenarbeit
- Garantie 66 – Das Qualitätsversprechen im Detail
- Technische Hinweise – Wichtige Informationen zur Planung
- Produktseiten – So lesen Sie unsere Übersichten
- Artikelnummer – Die Logik hinter dem Code
- Piktogramme – Die Symbole und ihre Bedeutung



IMPORTANT REMARKS

This catalogue is reserved for professionals only. The values published in this catalogue are rated values, which can slightly change for reasons related to the production process. The published data such as dimensions, materials, colours and technical data are valid at time of printing, and exclusively provided for informational purposes. The editor takes no responsibility for typographical and print errors, as well as for any differences in the products, pictures and data. PLANLICHT reserves the right to change the products at any time and without any notice. The Terms and Conditions of planlicht GmbH & Co KG (available on WWW.PLANLICHT.COM/AGB-LANDING/) shall apply.*

Key technical specifications, listed values as well as the pictogram bar relate to at least one but not necessarily all items of the respective luminaire family, exact details for each item can be found in the online web catalogue or in PLANLICHT sales documents and data sheets.

** The power output, luminous flux and colour temperature can be slightly different due to specific electronic components used in the manufacturing process. The power output and luminous flux can differ by +/- 10%. The colour temperature can differ by +/- 150 K. Luminous flux dynamic white at 2700 K.*

RELEVANT INFORMATION AT A GLANCE

- *Terms & Conditions – The Basis of Our Cooperation*
- *Guarantee 66 – Our Commitment to Quality*
- *Technical Notes – Essential Guidance for Planning*
- *Product Pages – How to Read Our Overviews*
- *Article Number – The Logic Behind the Code*
- *Pictograms – The Meaning Behind the Symbols*

IMPRINT

Publisher: planlicht GmbH & Co. KG, Vomp
Creative Concept: Katrin Atzinger
Graphic Design: Beatrice Praxmarer, Christoph Höflinger
© 2026



6134 Vomp, Austria, Au 25
Tel. +43-5242-71608, Fax +43-5242-71283
info@planlicht.com
WWW.PLANLICHT.COM



PROFIL- & SYSTEMLEUCHTEN

PROFILE & SYSTEM LUMINAIRES

WWW.PLANLICHT.COM